



Toyota Landcruiser 300 Series MY2022+ Predator & Toro Front Bar Fitting Instruction

IMPORTANT! – READ BEFORE INSTALLATION

- When installed in accordance with these instructions, the front protection bar does not affect the operation of the vehicles SRS airbags.
- This product must be installed exactly as per these instructions using only hardware supplied.
- Take a few moments to read instructions thoroughly before beginning work.
- In the event of damage to any bar component please contact OFFROAD ANIMAL to arrange repair/replacement of components.
- Do not use this product for any vehicle make or model other than that specified on these instructions.
- Do not remove labels from this product.
- This product and its fixings must not be modified in any way unless stated in these fitting instructions.
- The installation of this product is recommended for trained personnel.
- These instructions are correct at time of publication. OFFROAD ANIMAL cannot be held responsible for the impact of any changes subsequently made by the vehicle manufacturer. If you find something has changed, please contact us to let us know!
- During installation it is the duty of the installer to check correct operation/clearances of all components.
- If Instructions are to be printed for reference in the workshop, it is recommended that they are printed in colour, for best legibility.



GENERAL CARE AND MAINTENANCE

Use caution when cleaning with pressure washers, as they may compromise the product coating's integrity. Exercise care to avoid surface damage.

Only wash the product with a PH neutral car wash to prevent paint damage and discolouration.

Do not use acidic or alkaline based cleaning products.

Plastic parts may be maintained with silicone spray.

It is important to perform regular checks (pre/during/post trip or on an annual basis) on the installed product. More frequent checks may be required in extreme use cases. Checks include:

- Visual inspection for damage (eg. cracks, chips, dents etc.)
- Electrical wiring is not rubbing anything or worn out
- Bolts are torqued to correct specification (see torque guide below)

For touching up small stone chips, Offroad Animal recommends the following paint products:

- Dupli-Color Trim & Bumper Paint Black (TB101)
- VHT Hood, Bumper & Trim Paint Black (SP27)

BOLT TORQUE SETTINGS

Use the following bolt torques on all general fasteners, unless otherwise specified.

GENERAL FASTENERS	
Size	Torque Nm
M5	5 Nm
M6	9 Nm
M8	22 Nm
M10	44 Nm
M12	77 Nm

Use the following bolt torques on all structural front bar mount and tow point fasteners, and rear towbar fasteners, unless otherwise specified.

FRONT BAR MOUNTS AND TOW POINTS + REAR TOWBAR	
Size	Torque Nm
M10	57 Nm
M12	100 Nm
M14	164 Nm
M16	248 Nm

Always use a torque wrench to set correct torque settings. Ensure torque wrench is set to Nm unit of measurement. Otherwise perform conversion to lb-ft.



PARTS LISTING

IMPORTANT: Check all parts are present before beginning work! Contact OFFROAD ANIMAL if something is missing.

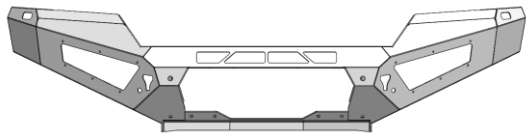
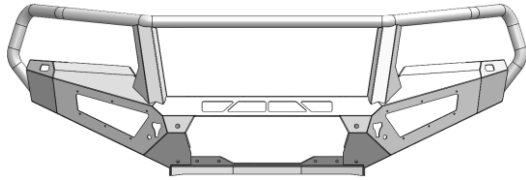
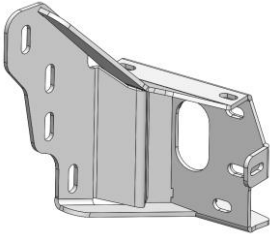
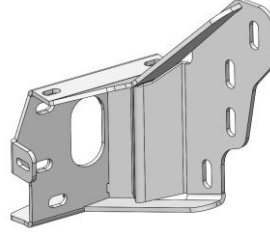
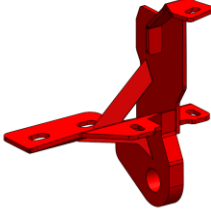
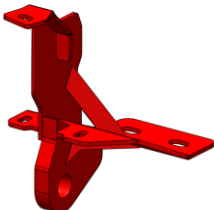
Main Parts – In the Box





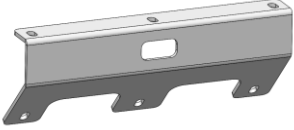
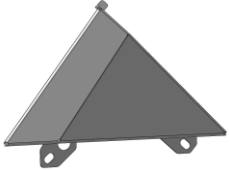
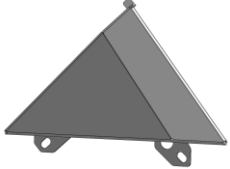
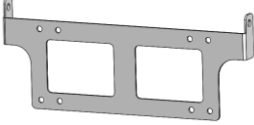
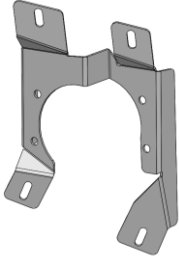
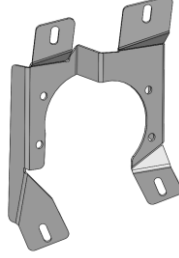
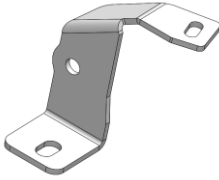

Qty	Part Number	Description	Image
1	FB-TLC-300-22-PR-ASM1	Toyota LC300 Predator Bar Weldment	
OR			
1	FB-TLC-300-22-TOR-ASM1	Toyota LC300 Toro Bar Weldment	
1	FB-TLC-300-22-PR-ASM2L	Toyota LC300 Impact Assy LH	
1	FB-TLC-300-22-PR-ASM2R	Toyota LC300 Impact Assy RH	
1	FB-TLC-300-22-PR-ASM3L	Toyota LC300 Predator - Tow Assy LH	
1	FB-TLC-300-22-PR-ASM3R	Toyota LC300 Predator - Tow Assy RH	

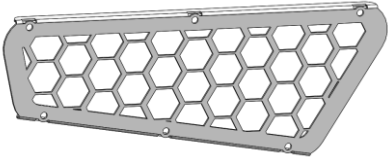
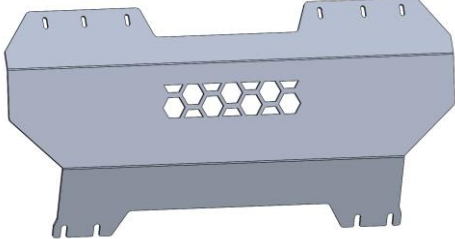
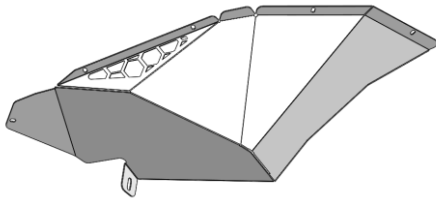
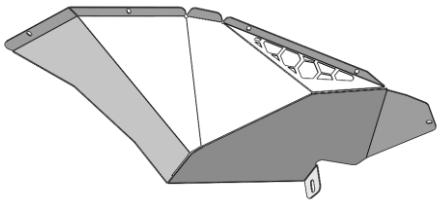

1	FB-TLC-300-22-PR-ASM4L	LC300 Front Headlight Washer Plug Assy LH	
1	FB-TLC-300-22-PR-ASM4R	LC300 Front Headlight Washer Plug Assy RH	
1	B-0666	Toyota LC300 Predator - Pan Brace	
1	B-0667L	Toyota LC300 Predator - Headlight Infill Panel LH	
1	B-0667R	Toyota LC300 Predator - Headlight Infill Panel RH	
1	B-0668	Toyota LC300 Predator - Number Plate Bracket	
1	B-0679L	Toyota LC300 - Fog Light Bracket LH	
1	B-0679R	Toyota LC300 - Fog Light Bracket RH	
1	B-0850L	Toyota LC300 Outer Chassis Brace LH	



1	B-0850R	Toyota LC300 Outer Chassis Brace RH	
2	B-0982	Toyota LC300 Grille Support Bracket Base	
1	B-0983L	Toyota LC300 Grille Support Bracket GX-Sahara LH	
1	B-0983R	Toyota LC300 Grille Support Bracket GX-Sahara RH	
1	M-0024	Toyota LC300 Predator - Centre Fairlead Mesh Panel	
1	M-0025L	Toyota LC300 Predator - Side Mesh Panel LH	
1	M-0025R	Toyota LC300 Predator - Side Mesh Panel RH	
1	M-0026L	Toyota LC300 Predator - Fog Light / Intercooler Mesh Panel LH	

1	M-0026R	Toyota LC300 Predator - Fog Light / Intercooler Mesh Panel RH	
1	U-0046	Toyota LC300 Predator - Centre Underpanel	
1	U-0047L	Toyota LC300 Predator - Side Underpanel LH	
1	U-0047R	Toyota LC300 Predator - Side Underpanel RH	
2	PWS-TOP-1000	Pinch Weld PWS51T - Top Bulb Seal 1000mm	No Image
1	FB-TLC-300- 22-PR-ADRCP	ADR Compliance Plate Landcruiser 300 Series	
1	FI Note	Fitting Instruction Note	No Image
1	OFA-LOGO	OFFROAD ANIMAL METAL LOGO	
1	TK-COM-PSEN- 6	Tape Kit – 6 Sensor Universal	
1	TK-FB-TLC- LC300-22	Tape Kit LC300	
GX TRIM LEVEL ONLY			
4	CPHP029	Plastic Hole Insert, 17.4MM, Black, Tigerlink Hardware CPHP029	

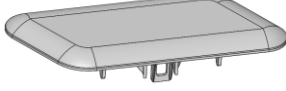

SAHARA / SAHARA ZX / GR SPORT TRIM LEVELS ONLY			
1	F-0014L	LC300 Headlight Washer Cover LH	
1	F-0014R	LC300 Headlight Washer Cover RH	
2	F-0022	LC300 Sahara ZX + GR Sport Sensor Holder	
TORO BARS ONLY			
1	B-0678L	Toyota LC300 Toro - Antenna Bracket LH	
1	B-0678R	Toyota LC300 Toro - Antenna Bracket RH	



Predator Small Parts – Contained in Small Parts Kit Bag

QTY.	PART NO.	DESCRIPTION
4	M6x16 HEX	Bolt Hex, M6x16x[1.0], GR8.8 ZP
3	M6x12 BHCS	SCREW, BUTTON HEAD CAP, M6X12X1 GR12.9 ZP
49	M6x16 BHCS BLACK ZINC	SCREW, BUTTON HEAD CAP, M6X16X1 GR12.9 BLACK ZP
7	M6 FLAT WASHER	M6 Flat Washer
49	M6 FLAT WASHER BLACK ZINC	M6 Flat Washer, BLACK ZINC
40	M6 FLANGE NUT	Flange Nut, M6x1 G8.8 ZP
10	M6CN3MM	CAGE NUT M6x2.6-3.5
4	M8 X 20 HEX	Bolt Hex, M8X20x1.25, GR8.8 ZP
2	M8 X 25 HEX	Bolt Hex, M8X25x1.25, GR8.8 ZP
4	M8 X 16 BHCS BZP	SCREW, BUTTON HEAD CAP, M8X16X1.25 GR12.9 BLACK ZP
6	M8 X 30 BHCS BLACK ZINC	SCREW, BUTTON HEAD CAP, M8X30X1.25 BLACK ZP
8	M8 FLAT WASHER	M8 Flat Washer
10	M8 FLAT WASHER- BLACK ZINC	M8 Flat Washer - BLACK ZINC
2	M8 NYW	Washer, M8, Nylon
2	M8 FLANGE NUT	Flange Nut, M8x1.25 G8.8 ZP
2	M8 NYLOC	NYLOC SELF LOCKING NUT, ST STL A2 ISO
4	M10 x 25	Bolt Hex, M10X25x[1.5], GR8.8 ZP
4	M10 x 30	Bolt Hex, M10X30x[1.5], GR8.8 ZP
4	M10 Flat Washer	M10 Flat Washer
12	M10 FW LHD	WASHER, FLAT M10X28.5X2.5
8	M10 FLANGE NUT	Flange Nut, M10x1.5 G8.8 ZP
14	M12X30	Bolt Hex, M12X30x1.75, GR8.8 ZP
2	M12x100	Bolt Hex, M12X100x1.75, GR8.8 ZP
2	M12x30x1.25	Bolt Hex, M12X30x1.25, GR8.8 ZP
10	M12 FLAT WASHER	M12 Flat Washer
10	M12 FW LHD	M12 FW Large Heavy Duty
14	M12 FLANGE NUT	Flange Nut, M12x1.75 G8.8 ZP
2	M12 Nyloc nut	M12 NYLOC NUT
2	T-0057	Toyota LC300 Tow Point Crush Tube

Toro Small Parts – In addition to above

QTY.	PART NO.	DESCRIPTION
6	M8x20 BHCS BLACK ZINC	SCREW, BUTTON HEAD CAP, M6X16X1 GR12.9 BLACK ZP
6	M8 FLAT WASHER- BLACK ZINC	Flange Nut, M6x1 G8.8 ZP





TOOLS REQUIRED

The following tools will be required to install the product.

Hand Tools	Power Tools	Workshop Supplies
Metric Socket Set 8-19mm	Electric/Air Impact Driver (Optional)	Panel Stand or Soft Blanket
Socket Extension Bar		Isopropyl Alcohol
Metric Spanner Set 10-19mm		Clean Rag
Hex (Allen) Key Set 4-6mm		Cable Ties
Trim Puller Tool		Masking Tape
Flat Blade Screwdriver set		Marker Pen
Phillips Head Screwdriver set		Black Automotive Paint
Utility Knife		Scotch Brite or Fine Sandpaper
Side Cutters		Automotive Sealant/Adhesive (Sikaflex 227 or Equiv)
Pliers		Bucket (optional)
Soft face hammer (optional)		Hose Clamp (optional)

WORKSHOP SAFETY

It is the responsibility of the installer to always complete works in a safe manner. Make sure the following safety equipment is available and precautions are observed whilst fitting this product.

<p>Hearing Protection</p> 	<p>Always wear ear protection when using power tools.</p>
<p>Eye Protection</p> 	<p>Ensure eye protection is always worn when cutting or drilling.</p>
<p>Manual Handling</p> 	<p>Do not attempt to lift bar assemblies or rock sliders on your own.</p> <p>Always use two people to lift or use mechanical Lifting aid such as hydraulic lifting trolley.</p>
<p>Vehicle Support</p> 	<p>Always ensure vehicle is properly supported when working on it. Do not attempt to fit products whilst suspension work is being carried out. Do not work under a vehicle supported only by a jack.</p>



1. Open the bonnet.
2. Remove clips securing the top radiator cowling. Press down on the centre button of clip to unlock, then remove clip with trim tool.
3. Retain all clips for re-assembly.

TOOLS REQUIRED

Trim tool

FASTENERS

Retain factory

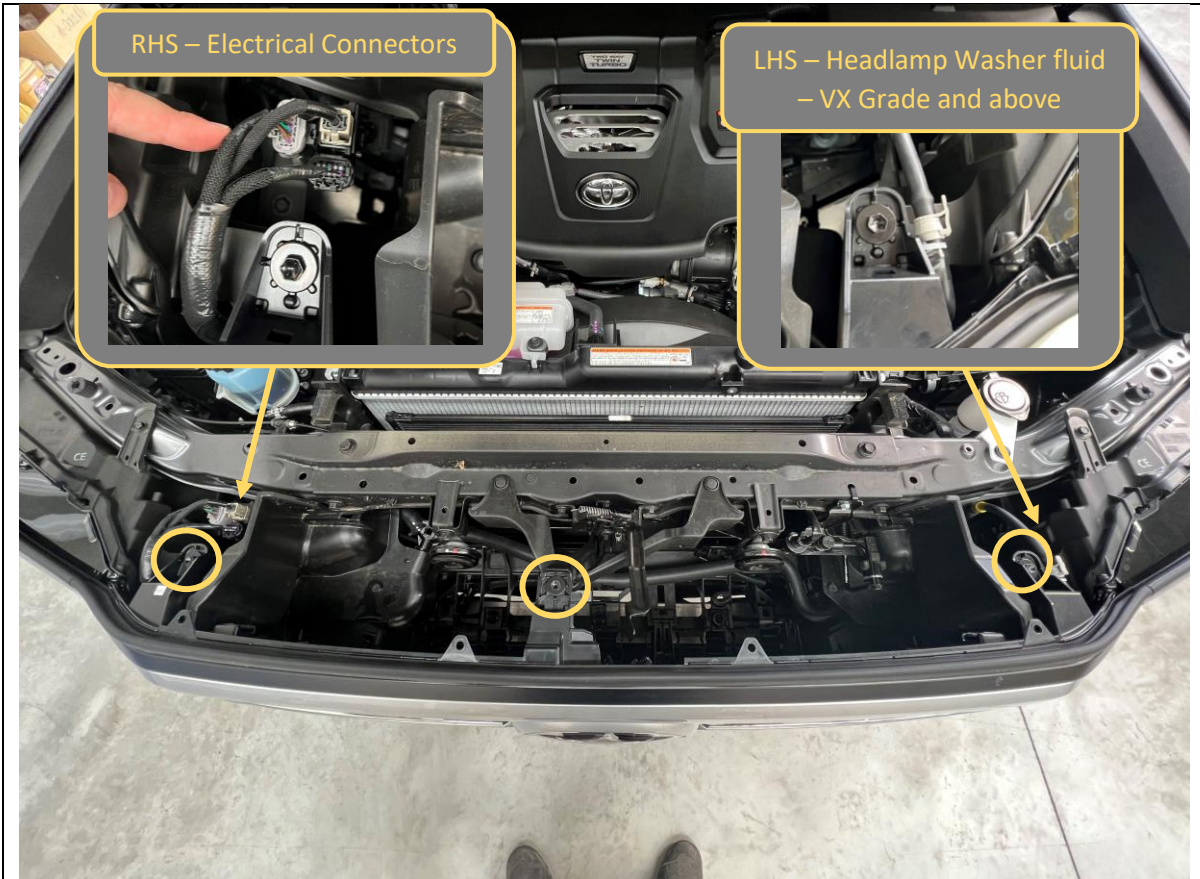

4. Remove the 3x bolts securing top of grille to body using 10mm socket.
5. Disconnect the electrical harness connectors (LHS) and headlamp washer fluid connector (RHS, VX models and above). Use a bucket and hose clamp if desired to prevent washer fluid spillage.

TOOLS REQUIRED

10mm socket
Bucket/hose clamp (optional)

FASTENERS

Retain factory

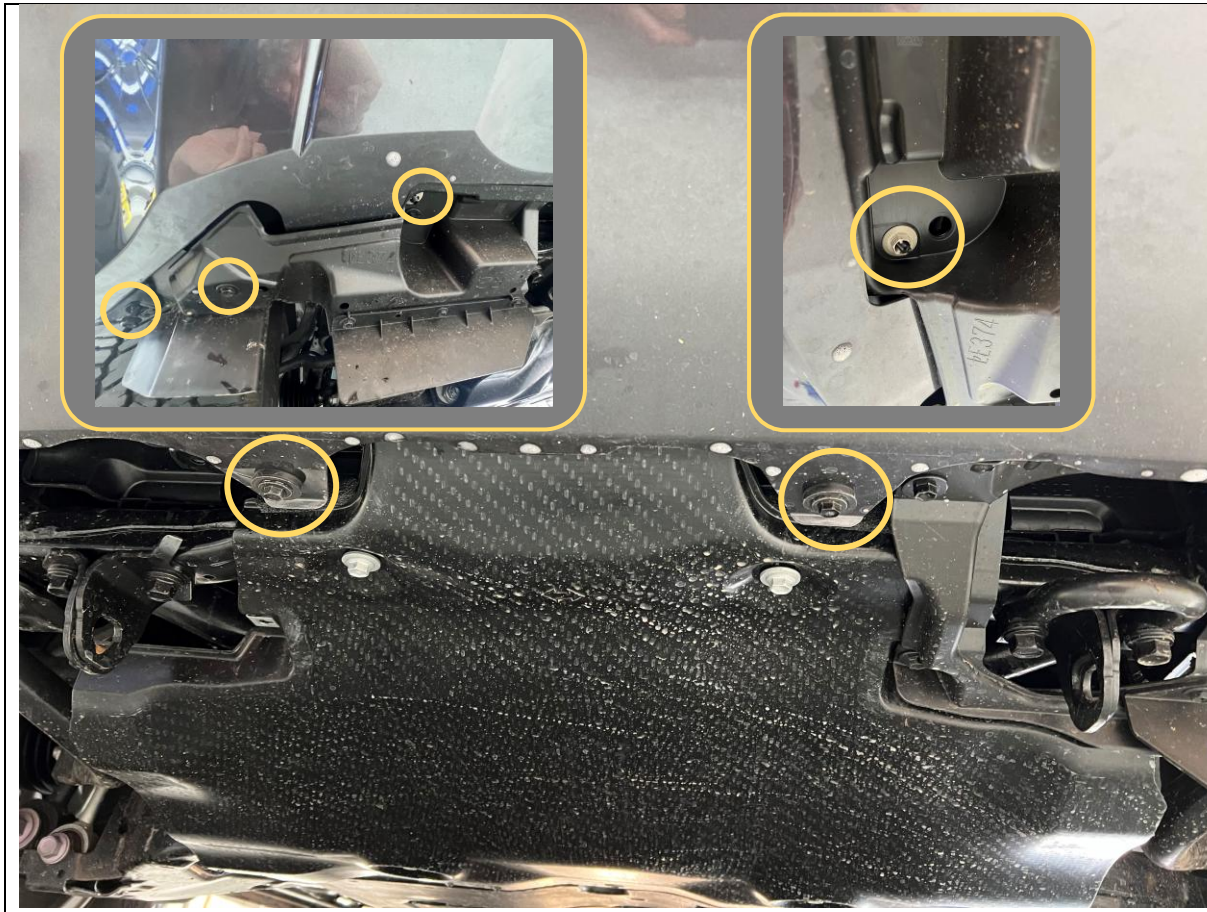

6. Remove the 10mm head screws securing the bumper to the lower cross member.
7. Remove the plastic nuts that also secure the bumper.

TOOLS REQUIRED

10mm socket

Trim tool

FASTENERS

Factory bolts (discard)



8. Remove clips securing wheel arch flare and inner guard liner by prying up center part of clip using a trim tool.
9. There are several clips securing each flare.

TOOLS REQUIRED

Trim tool

FASTENERS



10. In addition to the clips there are also button head screws. Remove these using 4mm Hex key.
11. Remove all fasteners securing the flare and inner arch liner. Complete on both sides of the vehicles.

TOOLS REQUIRED

4mm hex/Allen key

FASTENERS



12. Before removal of the flare, place masking tape in line with the bumper to guard panel line, this will assist in trimming flare later. Make sure to note the side to be cut on the tape.
13. Progressively release the clips securing the wheel arch flare to the bumper and front guard. Start from the bottom corner of the flare towards the front of the vehicle.
14. Use trim tool as required to assist releasing the clips.

TOOLS REQUIRED

Masking tape
Trim tool

FASTENERS



15. Remove the clip securing the front bumper skin to the body, using trim tool.
16. Complete on both sides of the vehicle.

TOOLS REQUIRED

Trim tool

FASTENERS

	
<p>17. Starting from the wheel arch, carefully pull the bumper away from the body of the vehicle to release the clips.</p> <p>18. Remove the bumper and set aside on a soft blanket or panel stand.</p>	<p>TOOLS REQUIRED</p>
	<p>FASTENERS</p>



19. Disconnect the fog light harness from the fog light.
20. Remove the fog lights from the bumper, by removing the 3x Philips head screws.
21. Remove both the electrical harness, and headlight washer pipes from the bottom half of the bumper (not grille), by prying out the clips using trim tool.
22. Complete on both sides of bumper.

TOOLS REQUIRED

Phillips head screwdriver
Trim tool

FASTENERS

Discard factory screws

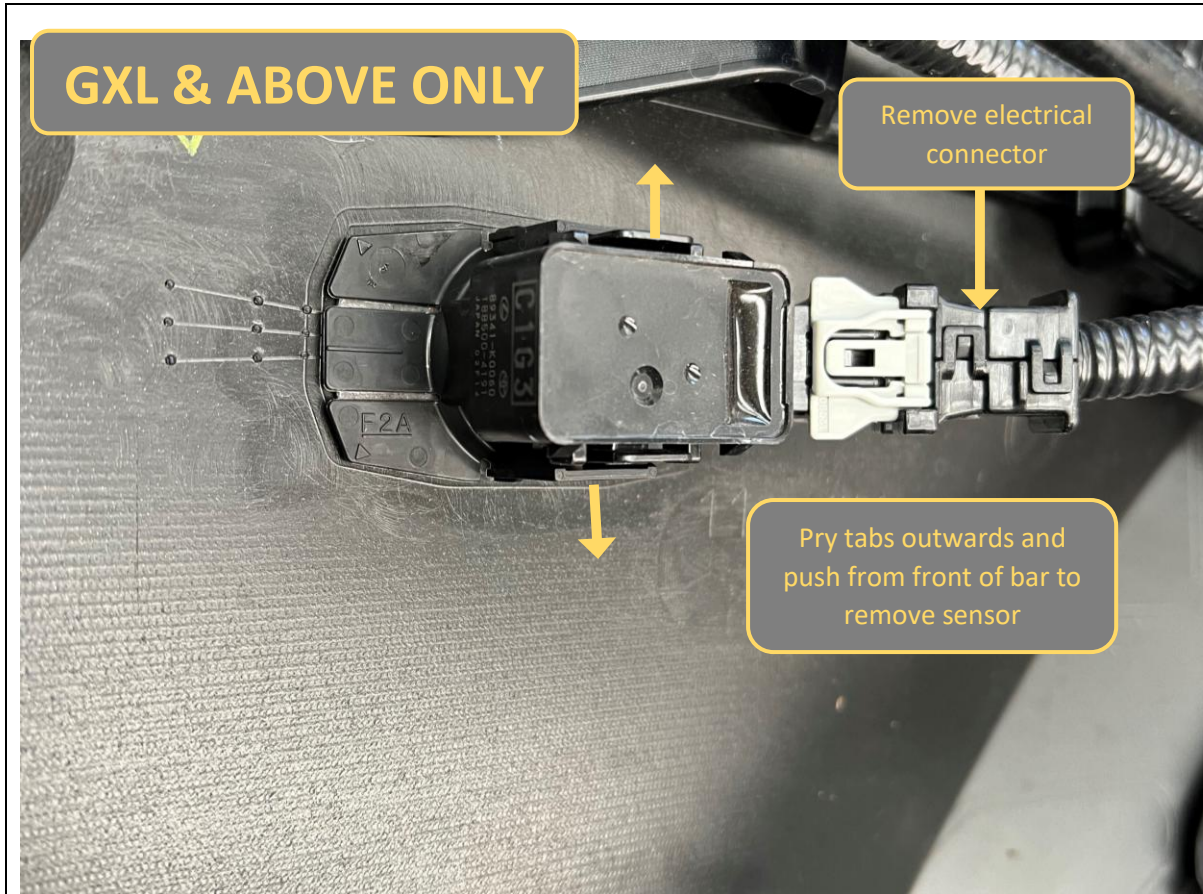

23. If car is equipped with parking sensors, disconnect the parking sensors from the loom by squeezing the tab, then pulling to disconnect the multi plug connector.
24. Pry the two grey retaining tabs on the sensor housing outwards whilst applying pressure to the face of the sensor from the front side of the bumper. The sensor should release from the housing. Remove from the rear side of the bumper.
- Take care to ensure the rubber isolation rings remain in place with the sensor.

TOOLS REQUIRED

FASTENERS



<p>25. If equipped, pull out headlight washer from bumper.</p> <p>26. Release tabs holding trim panel to headlight washer by prying away from headlight washer.</p> <p>27. Allow washer body to retract back into housing.</p>	<p>TOOLS REQUIRED</p>
	<p>FASTENERS</p>

<p>28. If vehicle is equipped, remove headlight washers from the bumper. Start by disconnecting the supply hose.</p> <p>29. Release the retaining spring by firmly pulling it as shown in the image.</p> <p>30. Once loose, remove the washer by sliding forward, removing through the front of the bumper.</p>	<p>TOOLS REQUIRED</p>
	<p>FASTENERS</p>

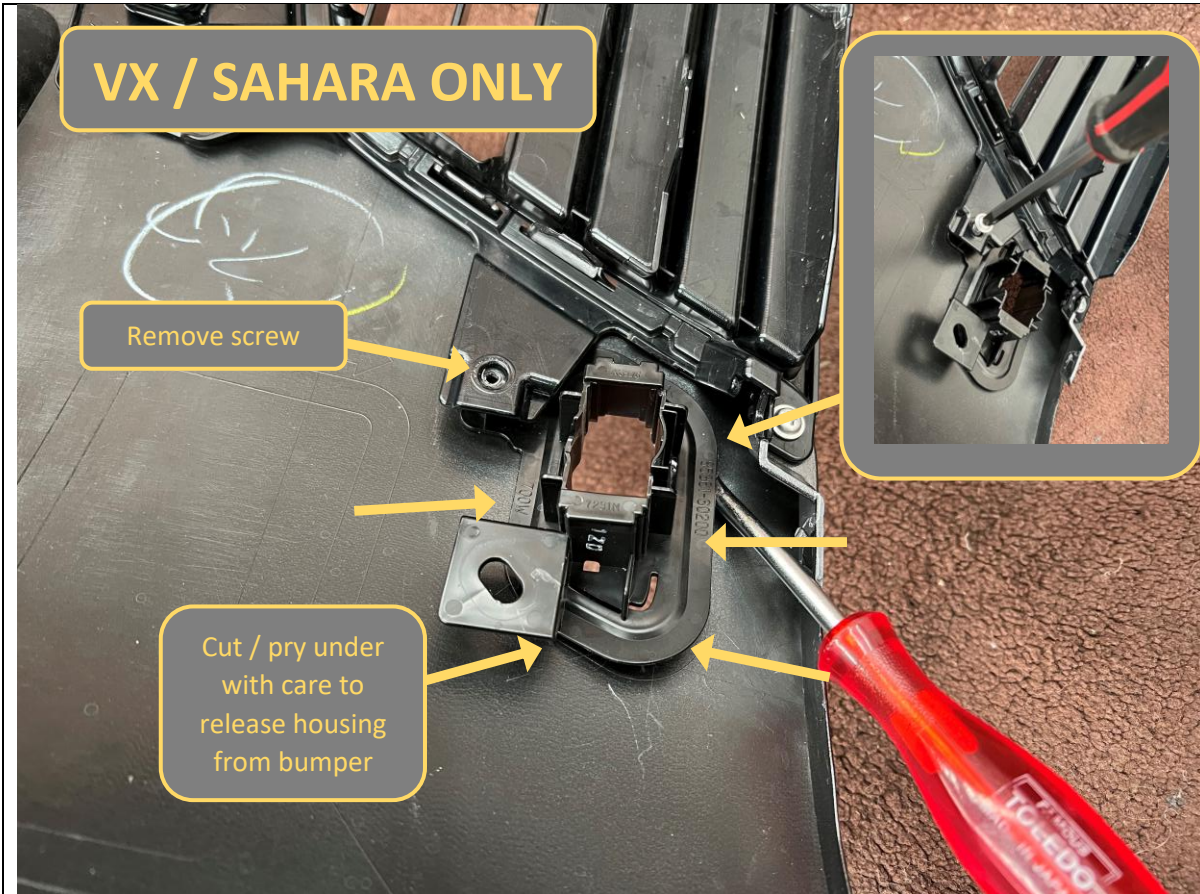

31. Remove the Phillips head screw holding the grille surround over the headlight washer.
32. Using a utility knife and trim tool carefully cut through the adhesive under the washer housing and pry it from the bumper.
33. Set aside housings taking care to note the correct positions for refitment.
34. Clean off all adhesive from face of washer mount.

TOOLS REQUIRED

- Phillips head screwdriver
- Utility knife
- Trim tool

FASTENERS

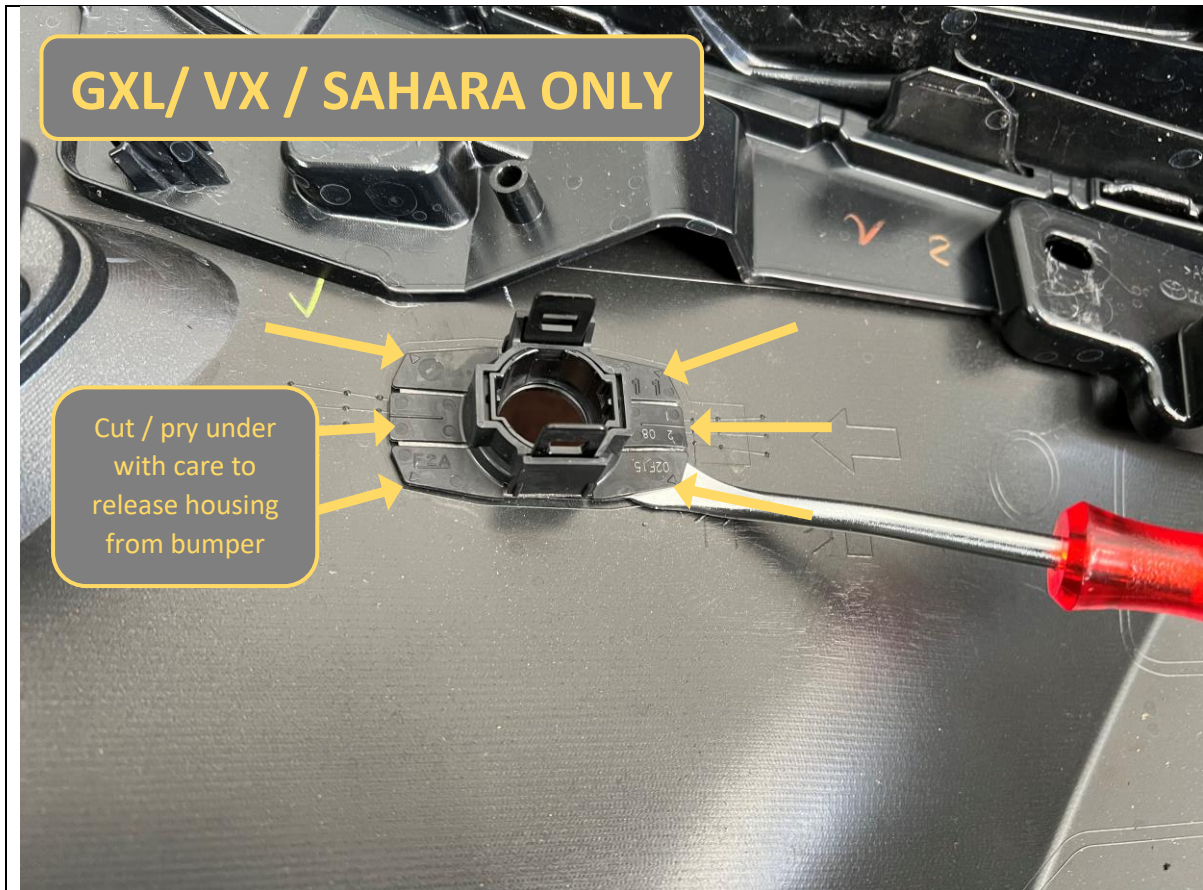

<p>35. Remove the sensor housing from the bumper for re-fitment to the bar.</p>	<p>TOOLS REQUIRED</p> <p>Utility knife</p> <p>Trim tool</p>
<p>36. Using a utility knife and trim tool carefully cut through the adhesive under the sensor housing and pry it from the bumper.</p> <p>37. Set aside housings taking care to note the correct positions for re-fitment.</p> <p>38. Clean off all adhesives from face of sensor mount.</p>	<p>FASTENERS</p>

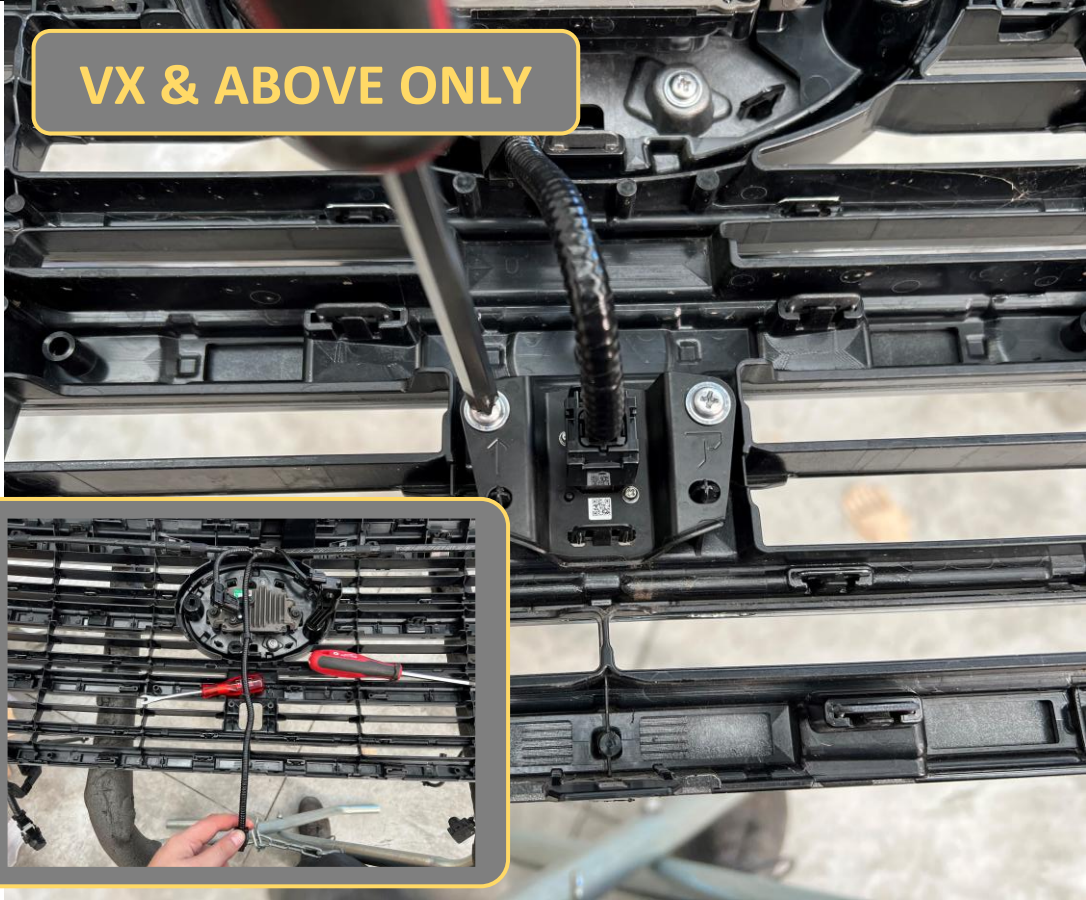
	
<p>39. If vehicle is equipped, remove the front camera from the grille.</p> <p>40. Disconnect the electrical harness, then remove the 2x Phillips head screws securing to bumper.</p> <p>41. Once removed, unclip the loom from the grille to allow cable to reach relocated position in bar.</p>	<p>TOOLS REQUIRED</p> <p>Phillips head screwdriver</p> <p>Trim tool</p>
	<p>FASTENERS</p>

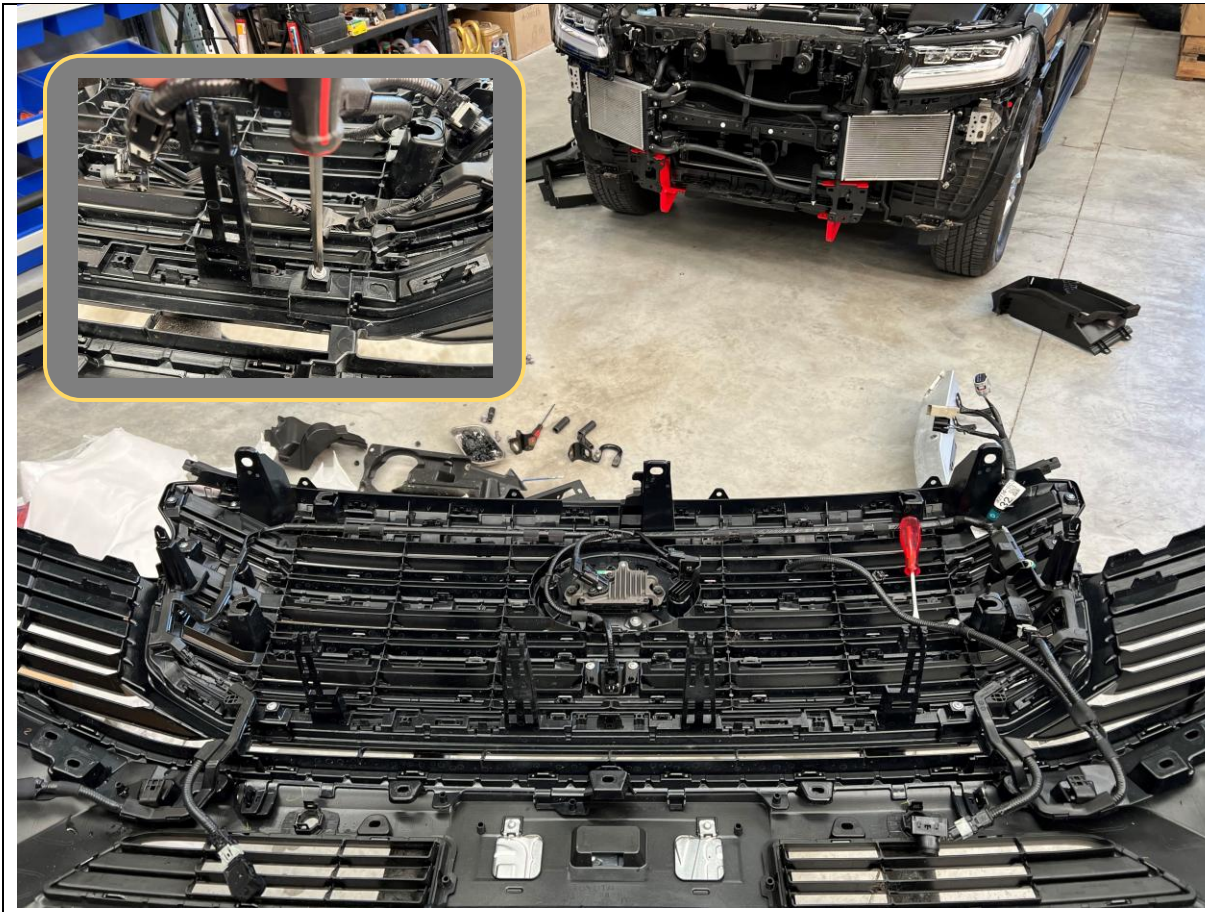

42. Separate the grille from the bumper.
43. The grille is secured by Phillips head screws and several moulded clips.
44. Begin by removing all Phillips head screws.
45. Progressively release clips, starting from outsides, and working towards the centre.
46. Once separated, set aside grille for re-fitment.

TOOLS REQUIRED

- Trim tool
- Phillips head screwdriver

FASTENERS

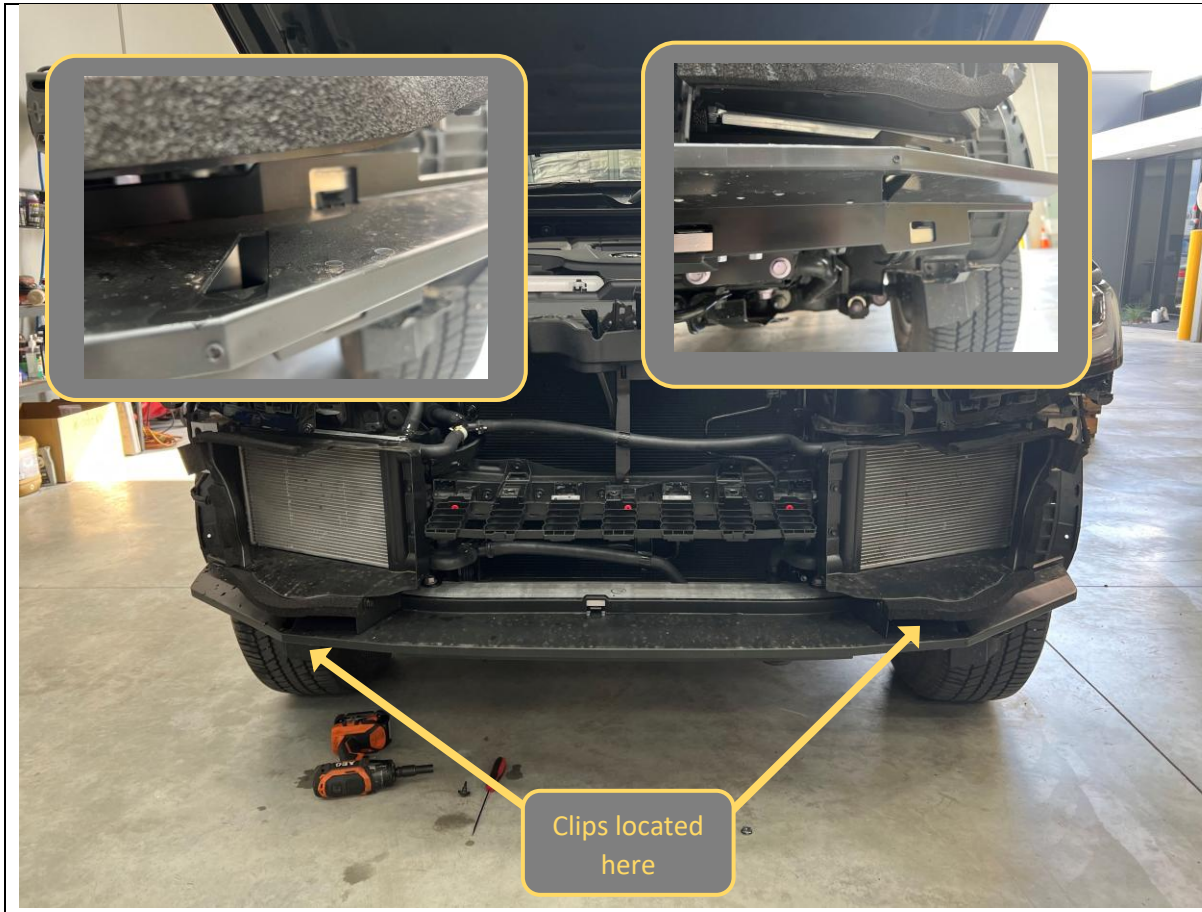

47. Remove the plastic covering the impact beam.

48. The plastic is secured by moulded clips in the front face, and clips on either end of the beam.

49. Remove and set aside the plastic impact beam.

TOOLS REQUIRED

FASTENERS

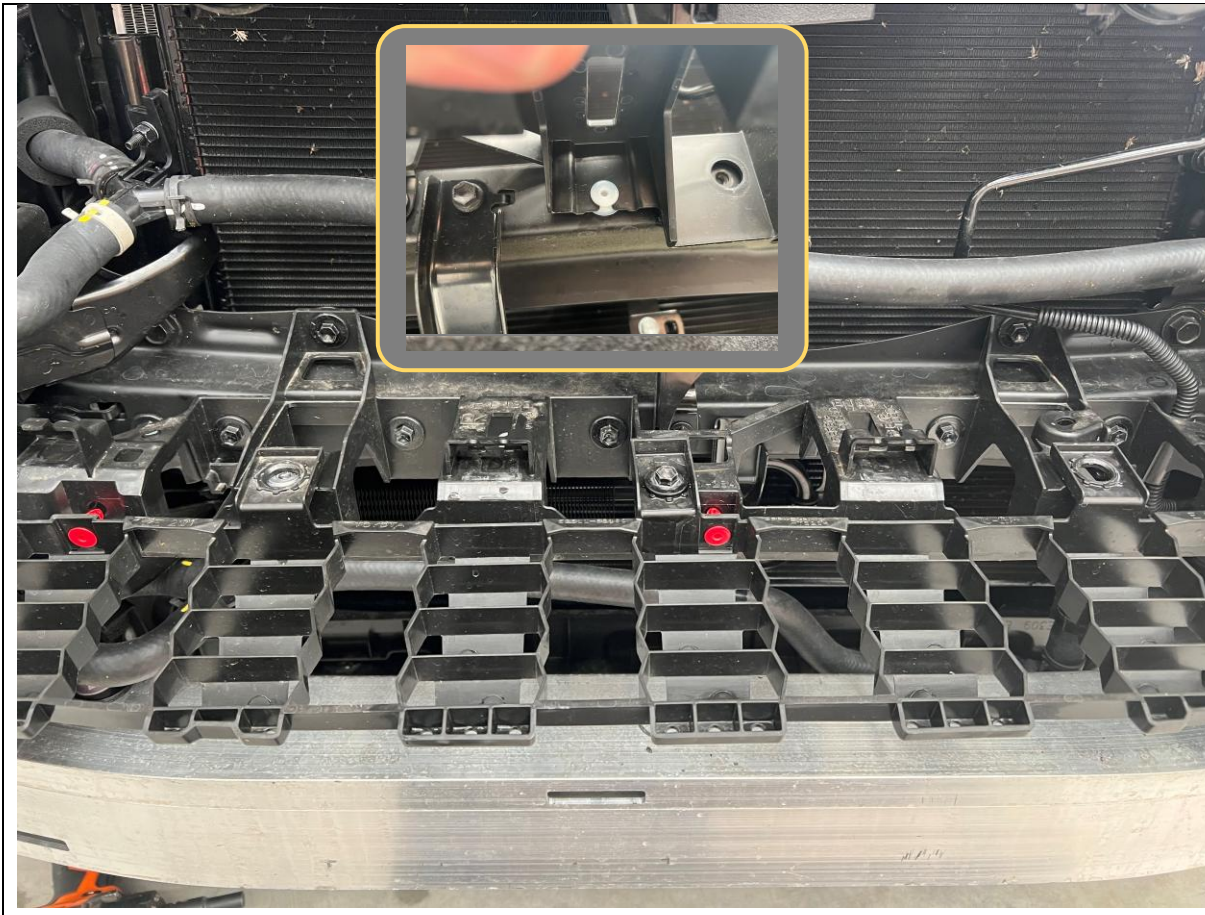

50. Remove the plastic concertina panel by removing the 10mm head bolts and clips securing it to the crossbeam on the car.

TOOLS REQUIRED

10mm socket/spanner

Trim tool

FASTENERS

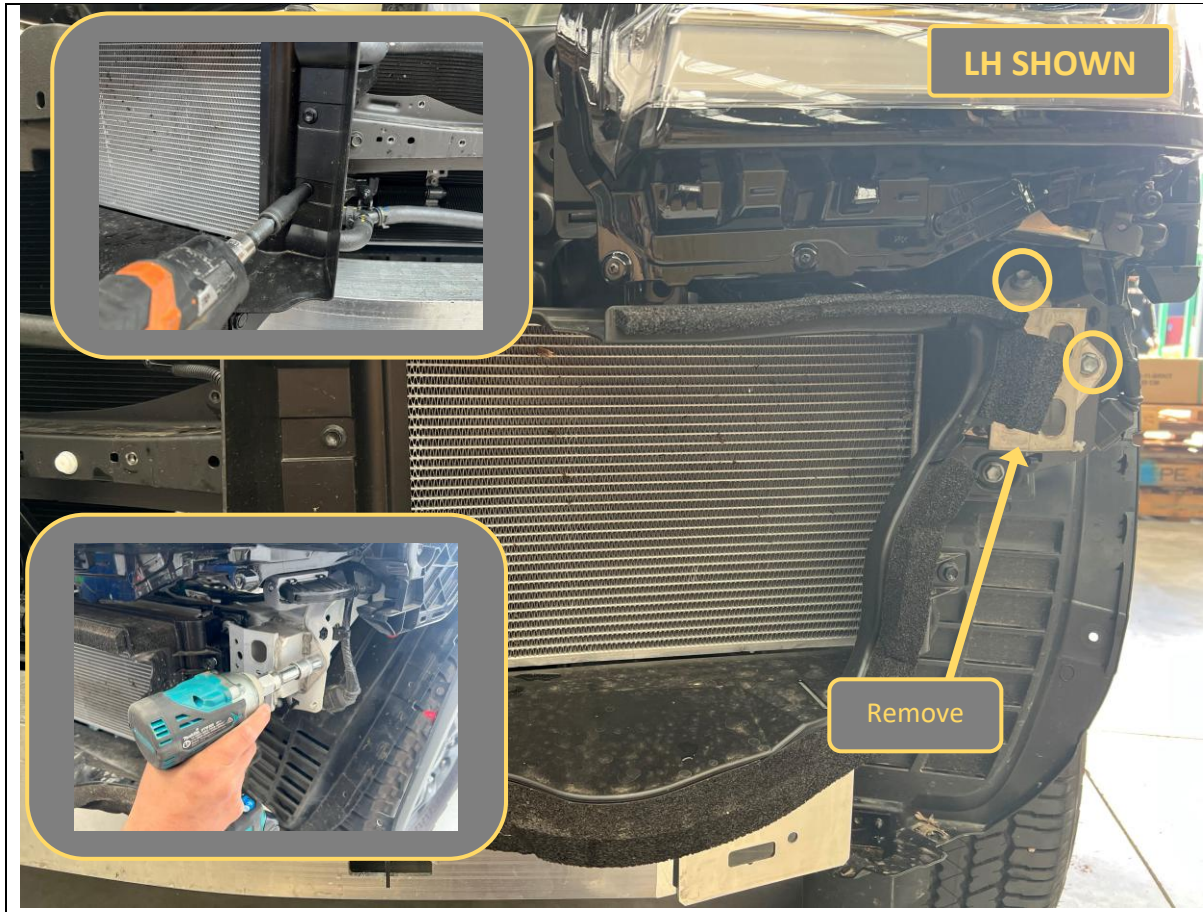

51. Remove the plastic intercooler air guides by removing the 4x 10mm head bolts securing them.
52. Remove the aluminum can under the headlight by removing 3x 12mm head bolts. Repeat for both sides of vehicle.

TOOLS REQUIRED

10mm socket/spanner
12mm socket/Spanner

FASTENERS

Retain factory



- 53. Mark trim line to air guide as shown in image.
- 54. Trim air guide along line marked using sharp utility knife.
- 55. Do not re-fit yet, it is easier to do so after mounts are tightened and adjusted.

TOOLS REQUIRED

- Marker pen
- Utility knife

FASTENERS

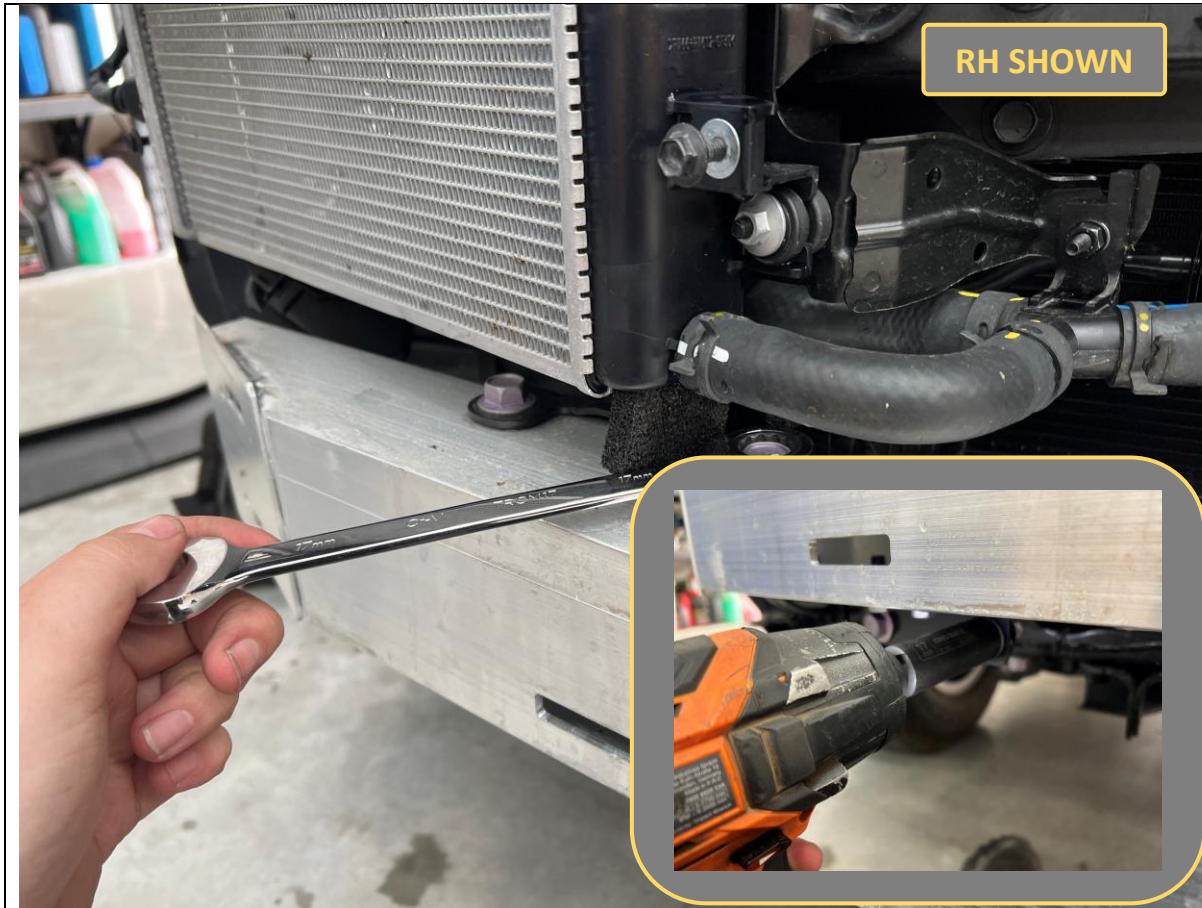

56. Remove the 4x 17mm head bolts holding the impact beam to the impact beam brackets.

There are 2x bolts on top and 2x bolts underneath on both sides.

57. Remove and set aside the aluminium impact beam.

TOOLS REQUIRED

17mm socket

17mm spanner

Extension bar

FASTENERS

8x 17mm head factory flange bolts

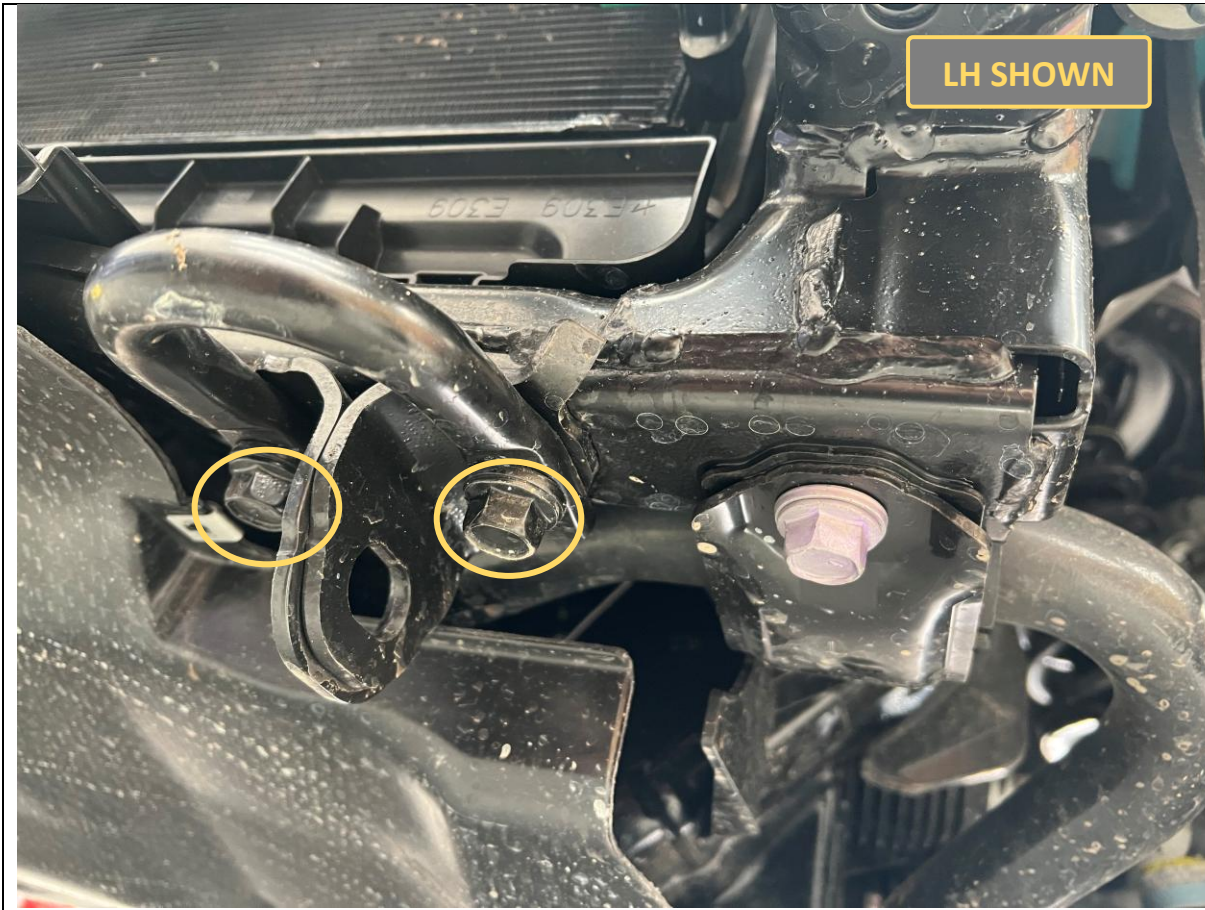

58. Remove the 2x 17mm head bolts securing the tow point to the lower chassis cross member.
59. Repeat for other side.

TOOLS REQUIRED

17mm socket

FASTENERS

4x 17mm head factory flange bolts

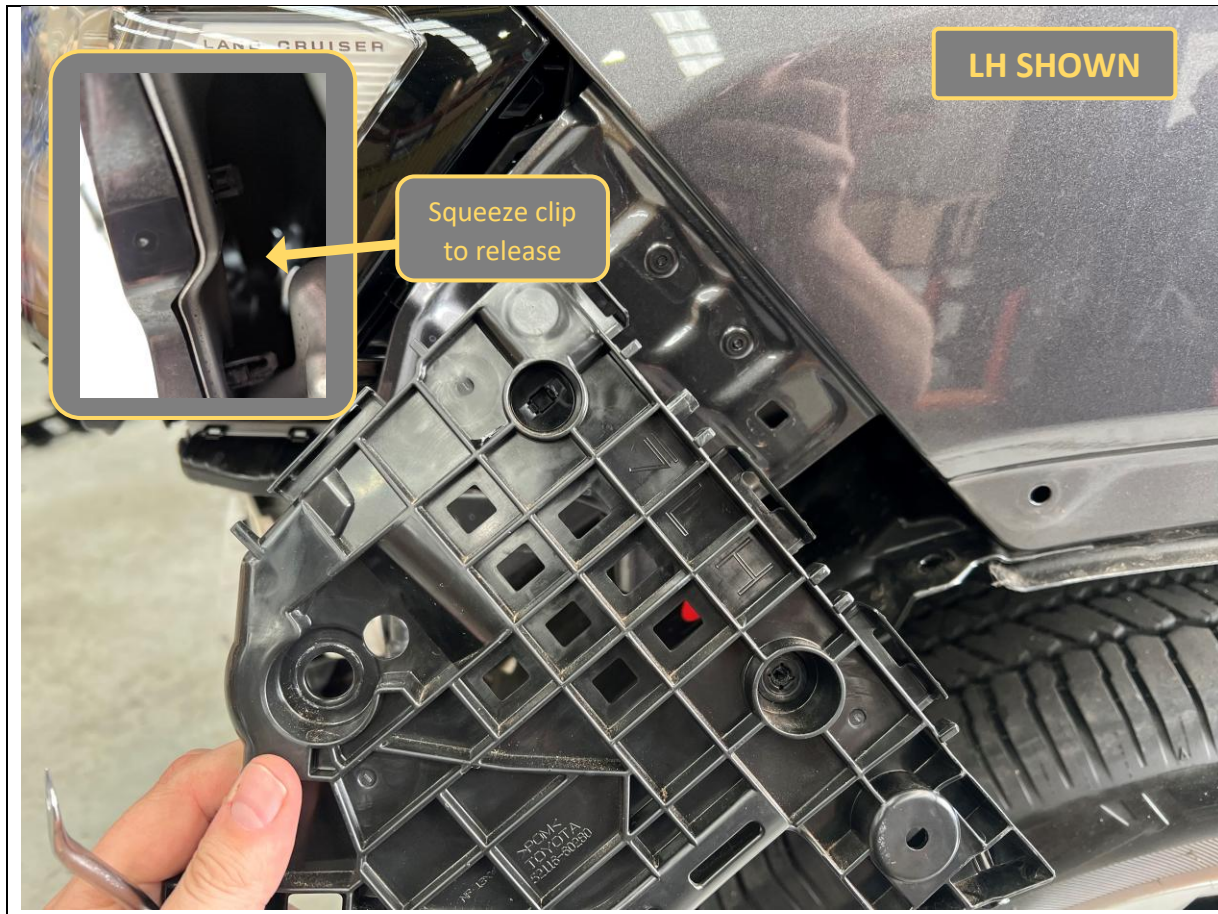

60. Remove the plastic bumper retainers by removing the Phillips head and 10mm head screws, then prying out the large clip from behind using trim tool.

TOOLS REQUIRED

Phillips head screwdriver

10mm socket

Trim tool

FASTENERS

Phillips head screw



61. Clean the inside face of the quarter panel with isopropyl alcohol.
62. Also clean the highlighted face of the new headlight infill panel (see inset photo).

TOOLS REQUIRED

- Isopropyl alcohol
- Clean rag

FASTENERS



RH SHOWN

63. Press down on the arrow location and break the bulb of the supplied 3M Primer 94 ampule to activate the primer dispensing.

64. Apply 3M Primer 94 to the cleaned areas on both the quarter panel and headlight infill.

Important: allow at least 5 minutes for the primer to chemically bond to the surfaces.

TOOLS REQUIRED

FASTENERS

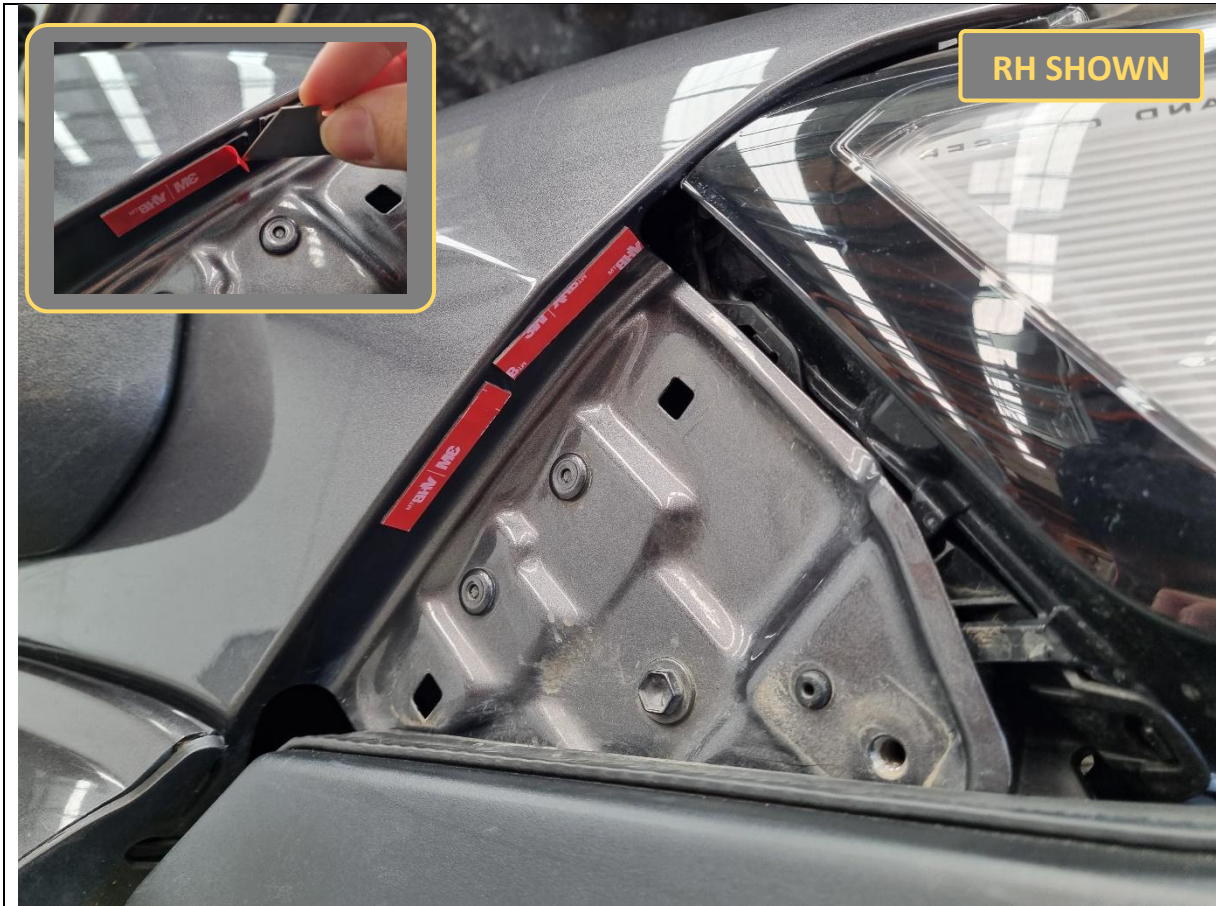

65. Apply 2x of the supplied wide tape pads to the quarter panel as shown.
66. Remove the backing film on the VHB tape (use a knife blade to assist, see inset photo).

TOOLS REQUIRED

Utility knife (optional)

FASTENERS



67. Carefully fit the headlight infill panel to the vehicle.

Ensure the lower 2x bolt holes line up with the vehicle.

Ensure the infill outer surface is sitting flush with the quarter panel.

68. Once properly aligned, press firmly to adhere top back edge of infill to the quarter panel.

TOOLS REQUIRED

FASTENERS



69. Mechanically secure the headlight infill to the car using 1x M6x16 black button head bolt and black washer through the captive nut at the front, and 1x M6x16 black button head bolt, black washer and flange nut at the rear.

70. Repeat infill installation for other side of car.

TOOLS REQUIRED

4mm hex/Allen key

FASTENERS

4x M6x16 black button head
4x M6 black flat washer
2x M6 flange nut

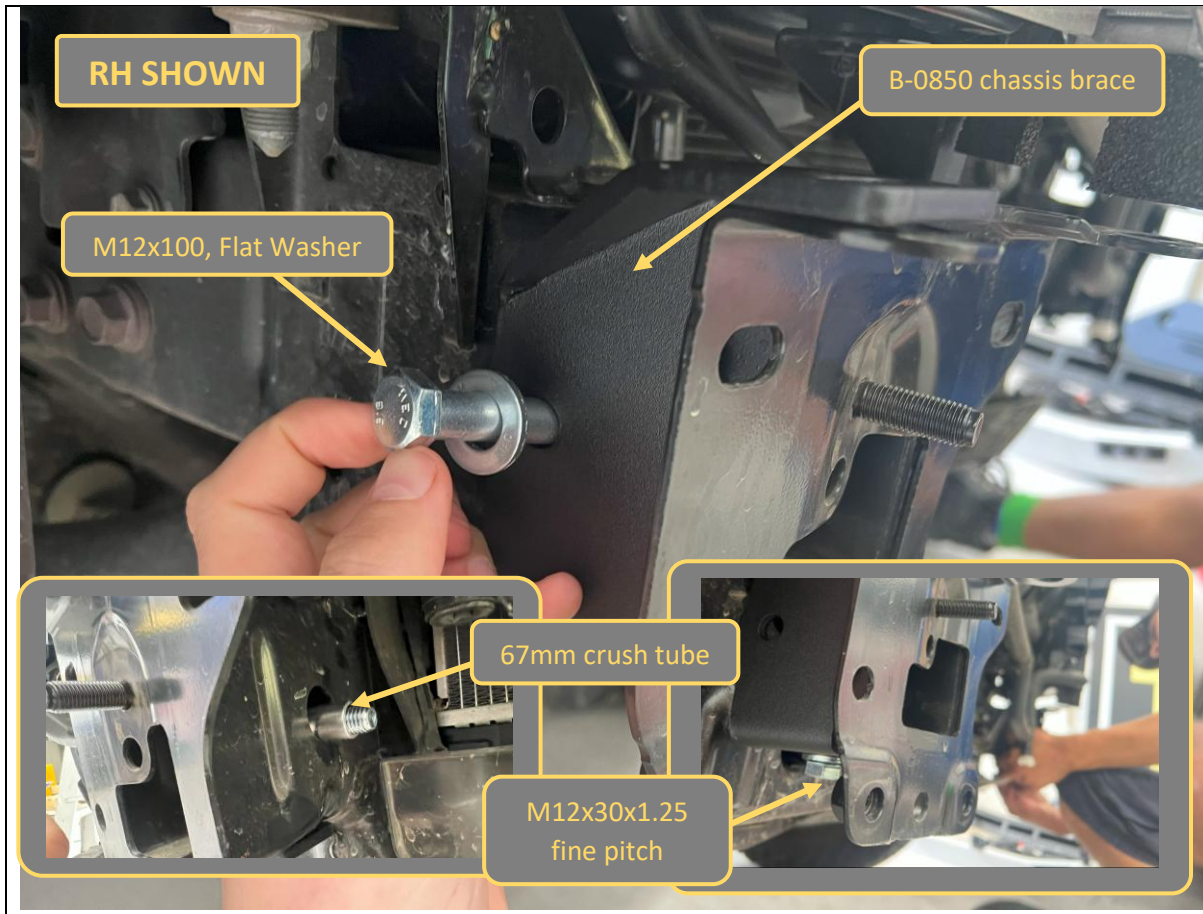

71. Loosely fit the B-0850 chassis brace to the outside of the chassis, using the supplied 1x M12x100mm bolt and flat washer; and 1x M12x30x1.25 fine pitch bolt and flat washer from underneath.
72. From inside of chassis rail feed 67mm crush tube over the M12x100 bolt.
73. Repeat for other side.

TOOLS REQUIRED

FASTENERS

1x M12x100 hex bolt
1xM12x30x1.25 hex bolt
2x M12 flat washer

per side

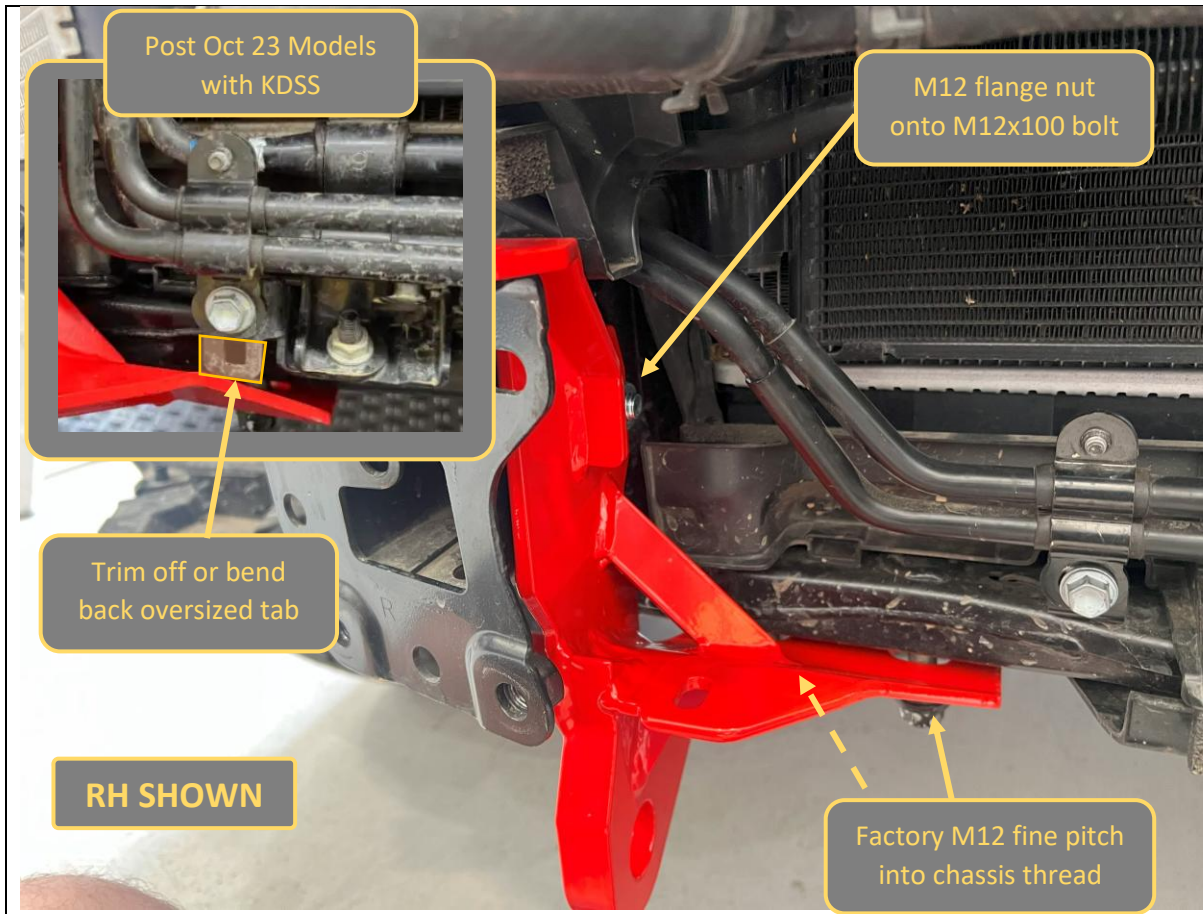

74. Loosely fit the tow point to the chassis. First secure with M12 flange nut on chassis brace. Then secure the bottom with the factory M12 fine pitch tow point bolts.

Note: Captive threads in chassis can be tight. Ensure bolts are not cross threaded and drive in manually with socket. Do not tighten at this stage.

75. Post Oct23 build vehicles with KDSS have a different pipe arrangement with an oversized mounting tab that may impede fitment. Trim or bend back tab as required for clearance. If trimmed, clean and paint any exposed metal to prevent corrosion.

76. Repeat for other tow point. Leave all bolts finger tight at this stage.

TOOLS REQUIRED

- Pliers
- Angle Grinder
- Paint pen
- Cleaning solvent

FASTENERS

- 2x M12 flange nut
- 4x factory M12 fine pitch bolts

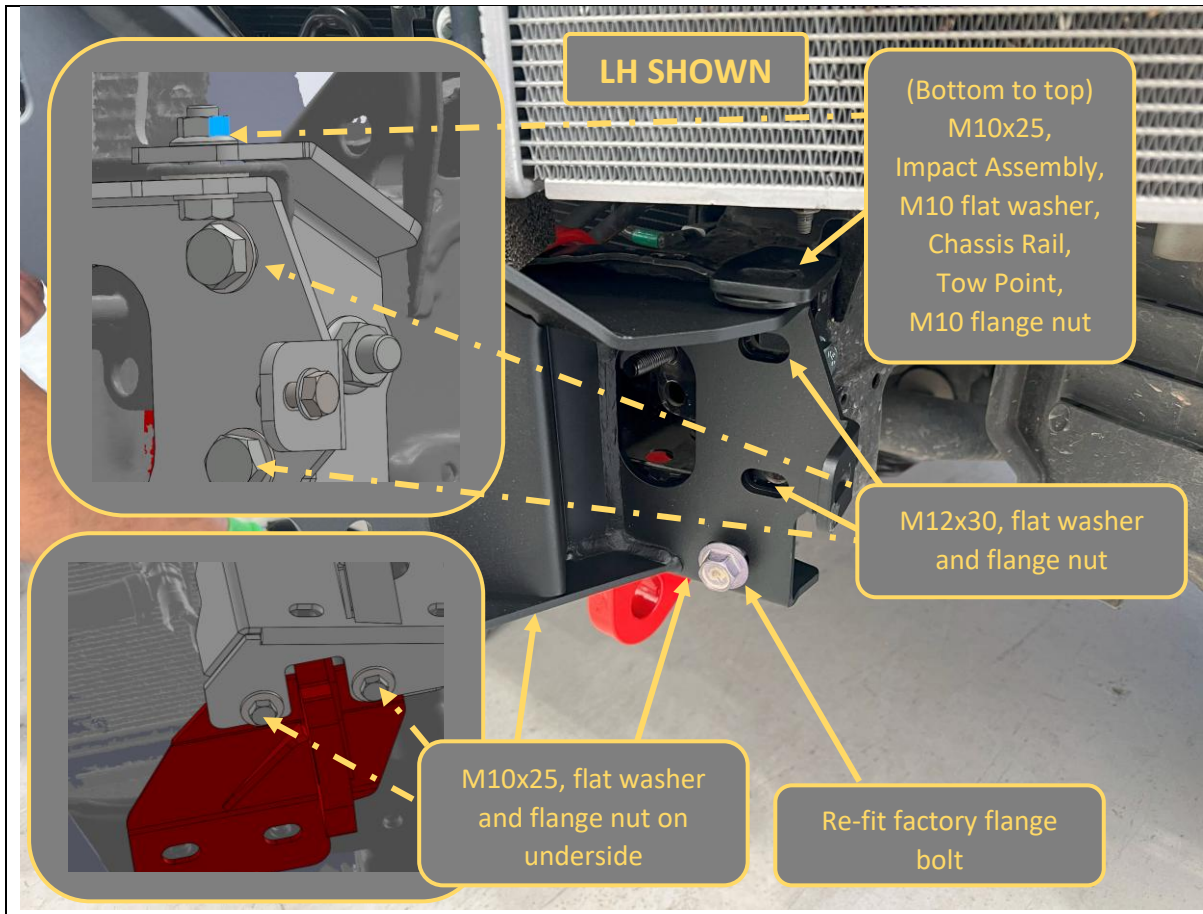

<p>77. Loosely fit the impact mounts to the chassis, re-using the original factory flange bolts.</p> <p>78. Loosely fit bolts securing impact assembly to tow points as per images above.</p> <p>79. Tighten tow point to chassis bolts in the following order:</p>	<p>TOOLS REQUIRED</p> <p>17/18mm socket</p>
<p>a) First, M12x100 bolt through the chassis rail.</p> <p>b) Next, factory M12 fine pitch bolts that secure tow point to lower cross member.</p> <p>80. Leave all bolts that secure tow point to the impact assembly, including the top flange bolts that go through chassis, loose at this stage.</p>	<p>FASTENERS</p> <p>4x M10x25 hex bolt 4x M10 flat washer 4x M10 flange nut</p> <p>3x M12x30 bolt 3x M12 flat washer 3X M12 flange nut</p> <p>2x factory fine pitch bolts</p> <p>Per side</p>

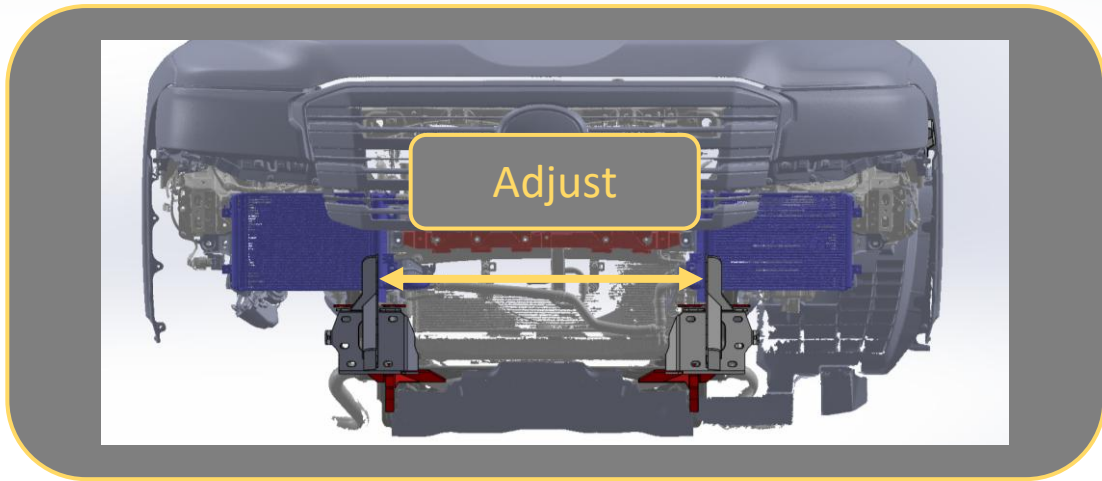
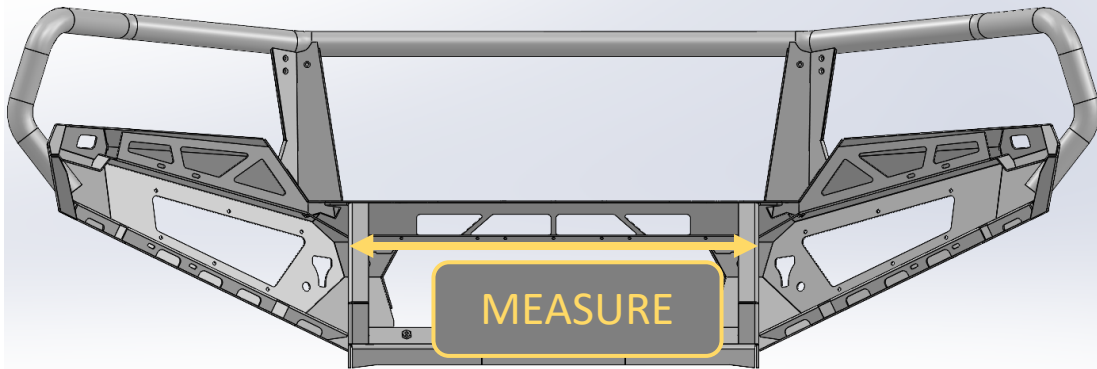

81. Measure distance between outside edges of the uprights on bar using tape measure. Write distance below for reference if required.

Bar Upright Width = _____mm

82. Adjust mounts by sliding mounts on slots, such that distance between outside edges of mounts is approximately 2mm less than bar.

83. Secure and tighten mounts. Tighten bolts that secure the tow point to chassis first, then impact assembly to tow point bolts.

TOOLS REQUIRED

Tape measure

16/17/18mm socket

FASTENERS



84. Re-fit trimmed air guides using factory fasteners.

TOOLS REQUIRED

10mm socket/spanner

FASTENERS

Factory bolts

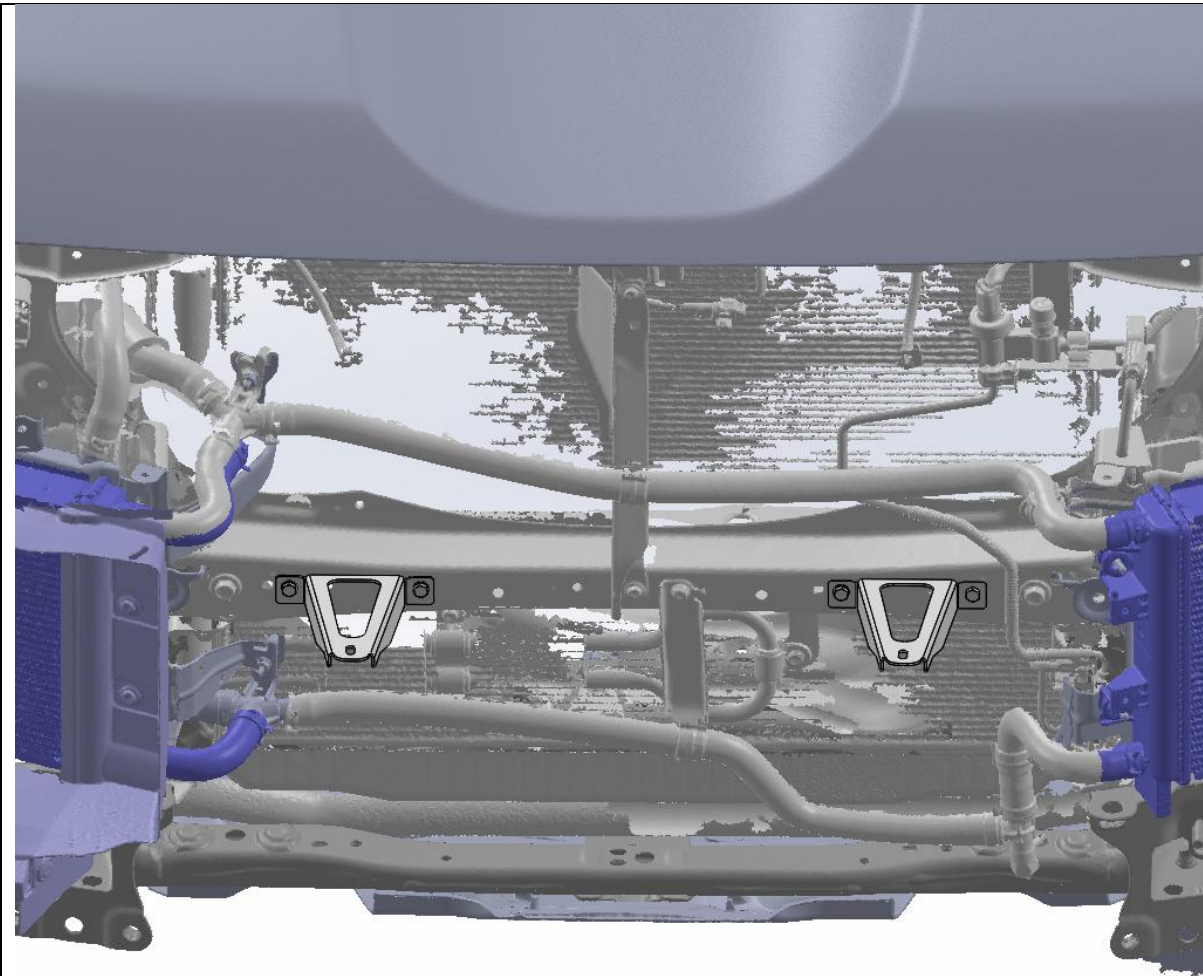

85. Fit the 2x grille support base brackets to the M6 threaded points on the body crossmember using the supplied M6x16 hex bolts and washers.
86. Once brackets are fitted, re-fit the grille to the vehicle, using the original factory Fasteners.

TOOLS REQUIRED

10mm socket/spanner

FASTENERS

4x M6x16 hex head bolt
4x M6 flat washer



87. Prepare the secondary grille support brackets by cleaning, applying primer and tape pads.

Ensure tape is applied to the correct side of the bracket as shown (slotted surface bent away from the tape surface).

Important: allow at least 5 minutes for the primer to chemically bond to the surfaces before applying tape.

TOOLS REQUIRED

FASTENERS



88. Fit the 2x secondary grille support brackets to the underside of the grille, using the tape pads, such that the bracket aligns with the slotted end of the primary support bracket.

The secondary bracket should sit on TOP of the base bracket, as shown in the image.

89. Complete for both sides of the grille.

90. Secure each secondary support bracket to the base bracket using 1x M6x16 black button head bolt, black flat washer, and flange nut.

TOOLS REQUIRED

4mm Allen Key
10mm spanner/socket

FASTENERS

2x M6x16 black button head
2x M6 black washer
2x M6 flange nut

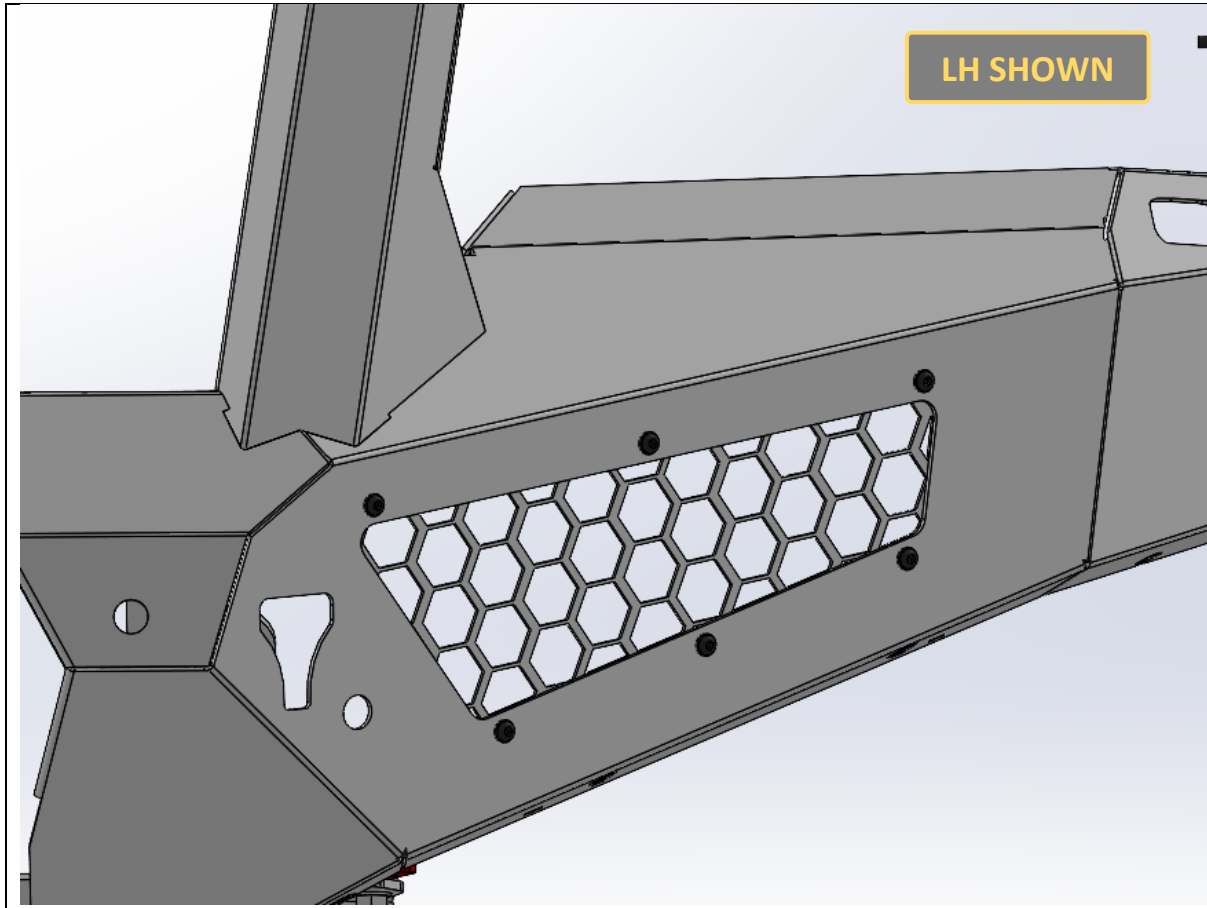

91. Fit the each mesh panel to the inside of the bullbar wing, using 6x M6x16 Button head bolts, black flat washers, and flange nuts.

TOOLS REQUIRED

4mm Allen Key
10mm spanner/socket

FASTENERS

6x M6x16 black button head
6x M6 black washer
6x M6 flange nut

per side

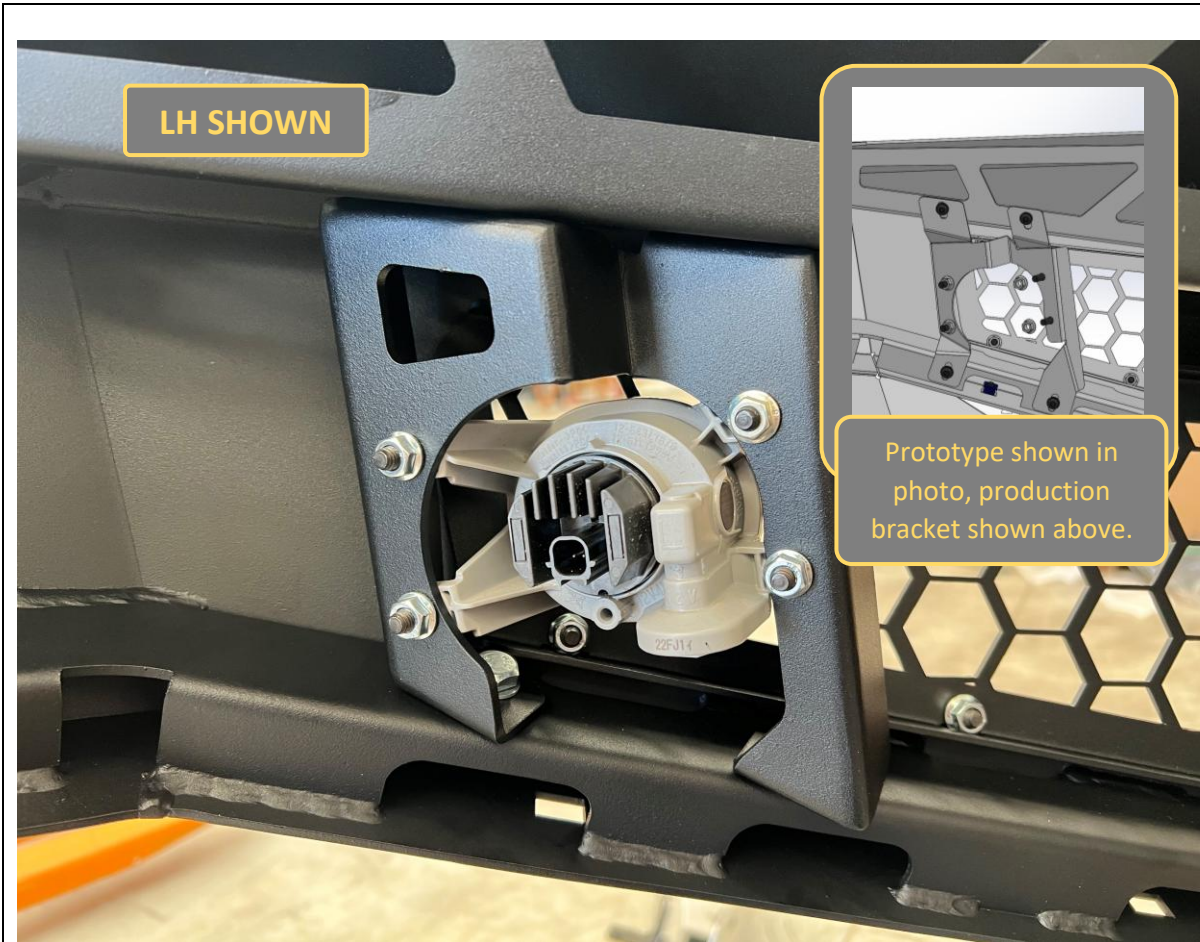

- 92. Re-fit the fog lamps to the fog light brackets using 4x M6X16 black button head bolts, black flat washers and flange nuts.
- 93. Secure and tighten using 4mm Allen key and 10mm spanner.
- 94. Fit the fog light bracket to the inside wing of the bar, using 4x M6X16 black button head bolts, black flat washers and flange nuts.

TOOLS REQUIRED

4mm hex/Allen Key
10mm spanner/socket

FASTENERS

8x M6x16 black button head
8x M6 black washer
8x M6 flange nut

per side

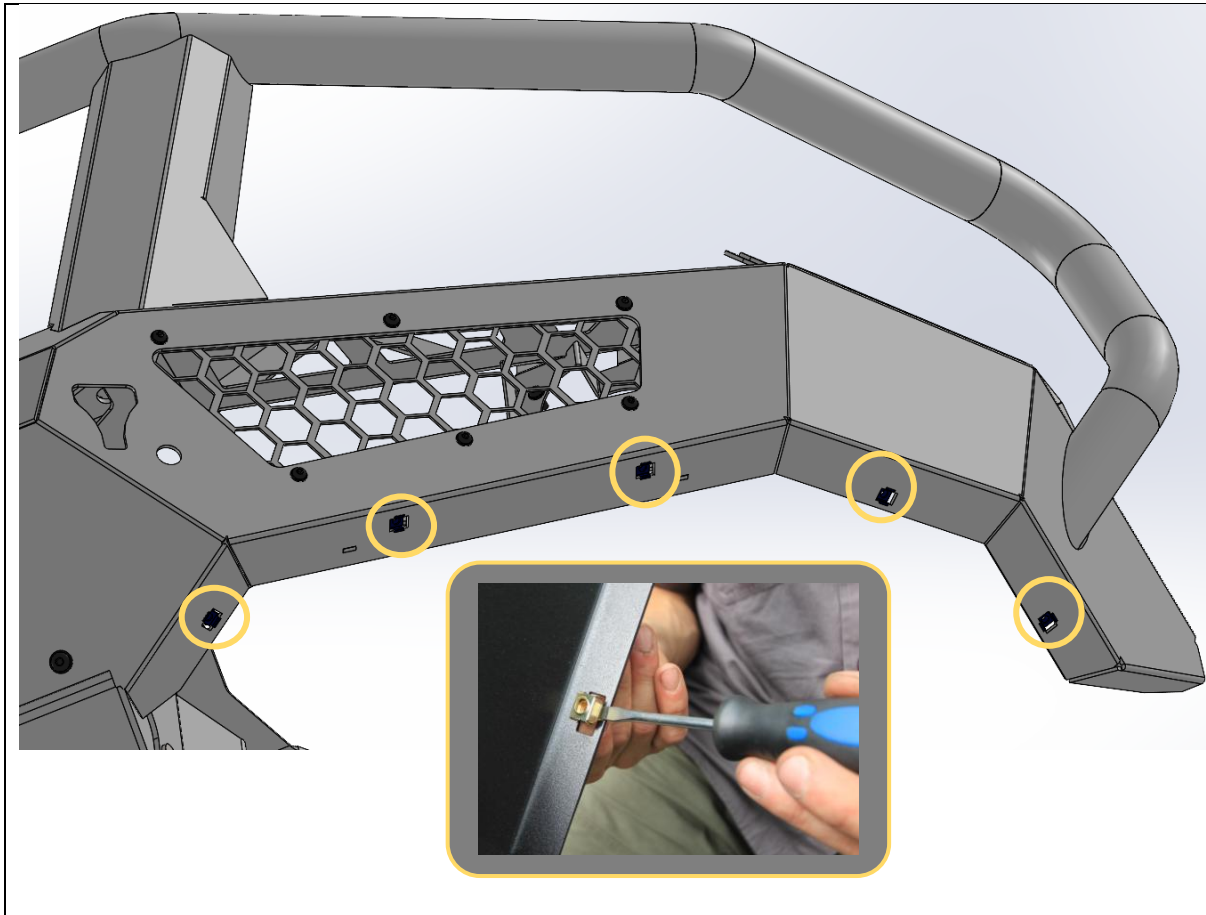

95. Fit 5x M6 cage nuts to rectangular slots in bottom of wing.

Use a small flat blade screwdriver to push the edge of the cage to engage with the slot to aid fitting.

96. Repeat for other side of bar.

TOOLS REQUIRED

Small flat blade screwdriver

FASTENERS

5x M6 cage Nut

per side

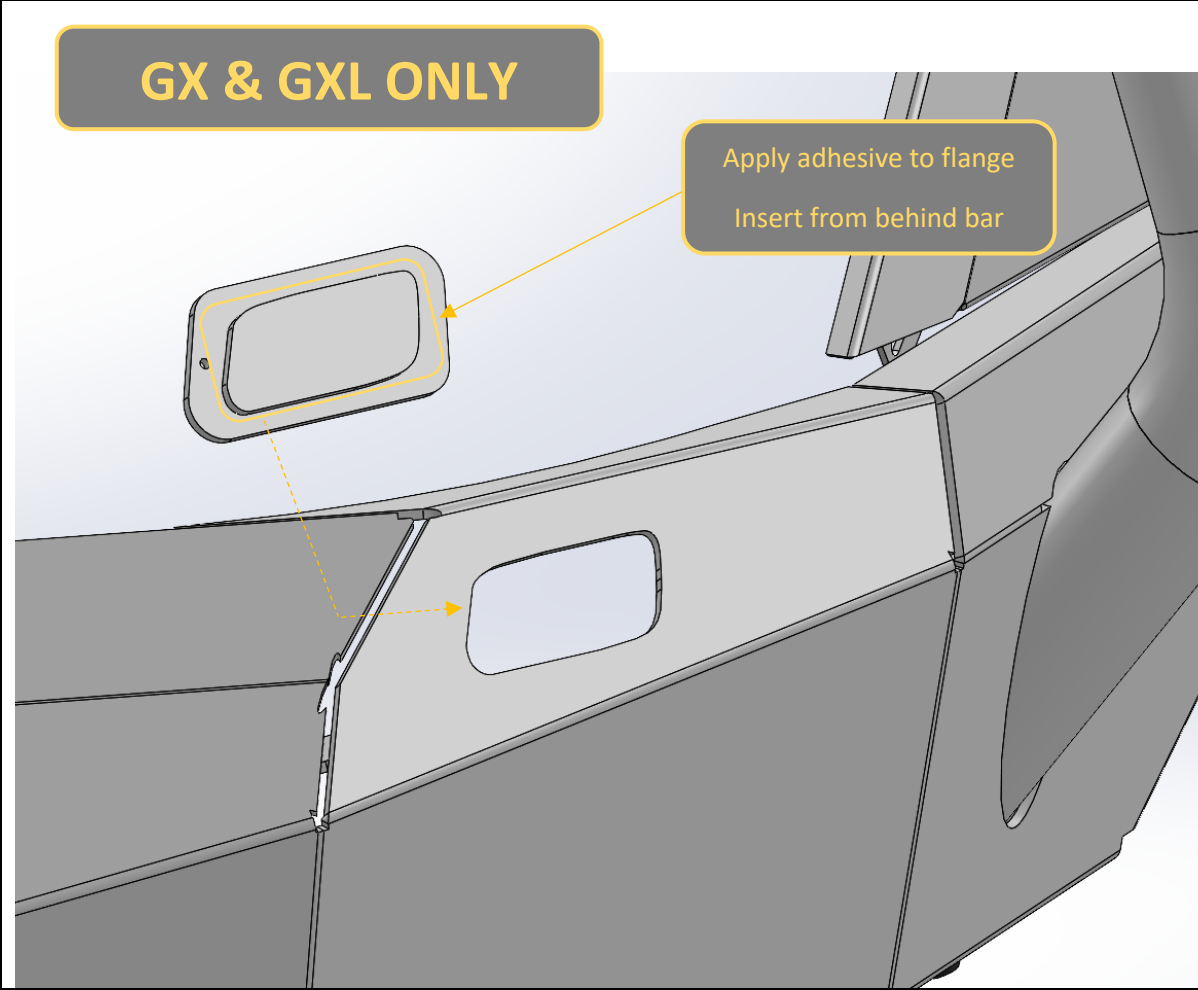
<div style="border: 2px solid orange; border-radius: 10px; padding: 5px; display: inline-block; background-color: #444; color: #fff; font-weight: bold; font-size: 1.2em; margin-bottom: 10px;">GX & GXL ONLY</div> 	
<p>97. If not fitting headlight washers install supplied plug plates, using Automotive grade adhesive (Offroad Animal recommends Sikaflex 227).</p>	<p>TOOLS REQUIRED</p> <p>Automotive adhesive</p>
	<p>FASTENERS</p>

VX & ABOVE ONLY



98. If equipped, refit headlight washers to bar. Fitment procedure is reverse of removal.
99. If the bar is not to be colour coded, paint the headlight washer covers black before re-fitting.
100. Thoroughly clean both the bar and headlight washers on faces where adhesion will occur.
101. Apply 3M Primer 94 to all mating surfaces.

Important: allow at least 5 minutes for the primer to chemically bond to the surfaces.
102. Apply the supplied narrow strips of VHB double side tape to the flange on the headlight washer housing.
103. Fit the housing to the cutout in the bar.

TOOLS REQUIRED

- Scotch Brite / sandpaper
- Matte black paint
- Isopropyl alcohol
- VHB double side tape

FASTENERS

<p>104. Re-fit the headlight washers into the housings, using the opposite of the removal procedure.</p> <p>105. Re-fit washer hoses to bar, and to headlight washers. Secure using cable ties.</p> <p>106. Once fitted pull out the washer assembly with long nose pliers and adjust the washer nozzles to squirt towards the headlights, final adjustment can be performed when the bar is fitted to the car.</p>	<p>TOOLS REQUIRED</p> <p>Long nose pliers</p>
<p>107. For Sahara ZX and GR Sport models, fit the supplied F-0014 cover cap instead of re-fitting the original cover.</p>	<p>FASTENERS</p>

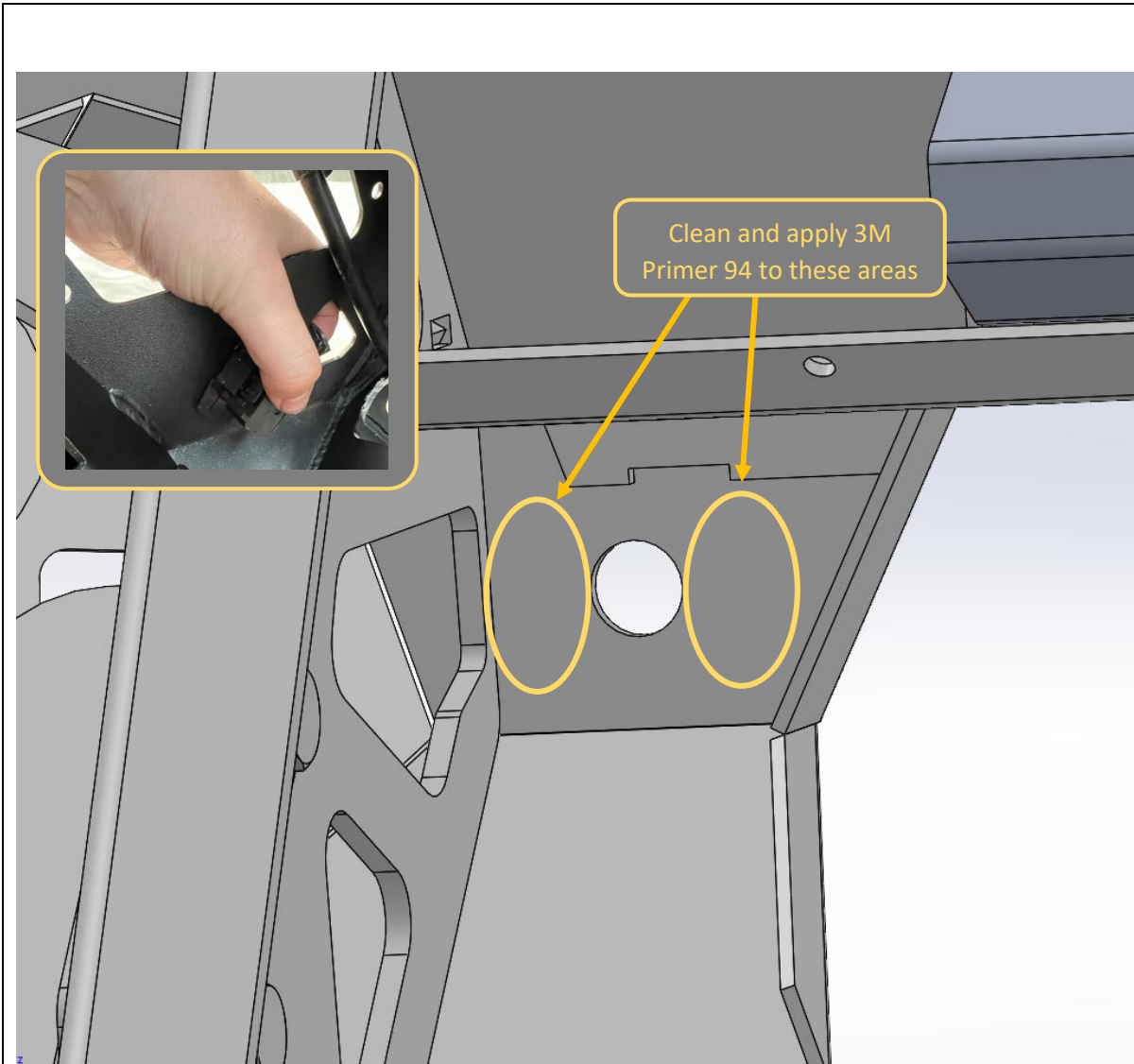

- 108. Re Fit parking sensors to the bar.
- 109. Clean area on back side of bar adjacent to sensor holes with isopropyl alcohol.
- 110. Re-fit sensors to housings to help locate housing during adhesion process.
- 111. Apply 3M Primer 94 to all mating surfaces.

Important: allow at least 5 minutes for the primer to chemically bond to the surfaces.
- 112. Using supplied tape VHB Pads, re-fit sensor housings to the bar.
- 113. If parking sensors are not fitted, fit cover plugs by pushing into hole from the outside.

TOOLS REQUIRED

- Isopropyl alcohol
- Clean rag
- 3M Primer 94 Ampule
- 3M Tape Pads

FASTENERS

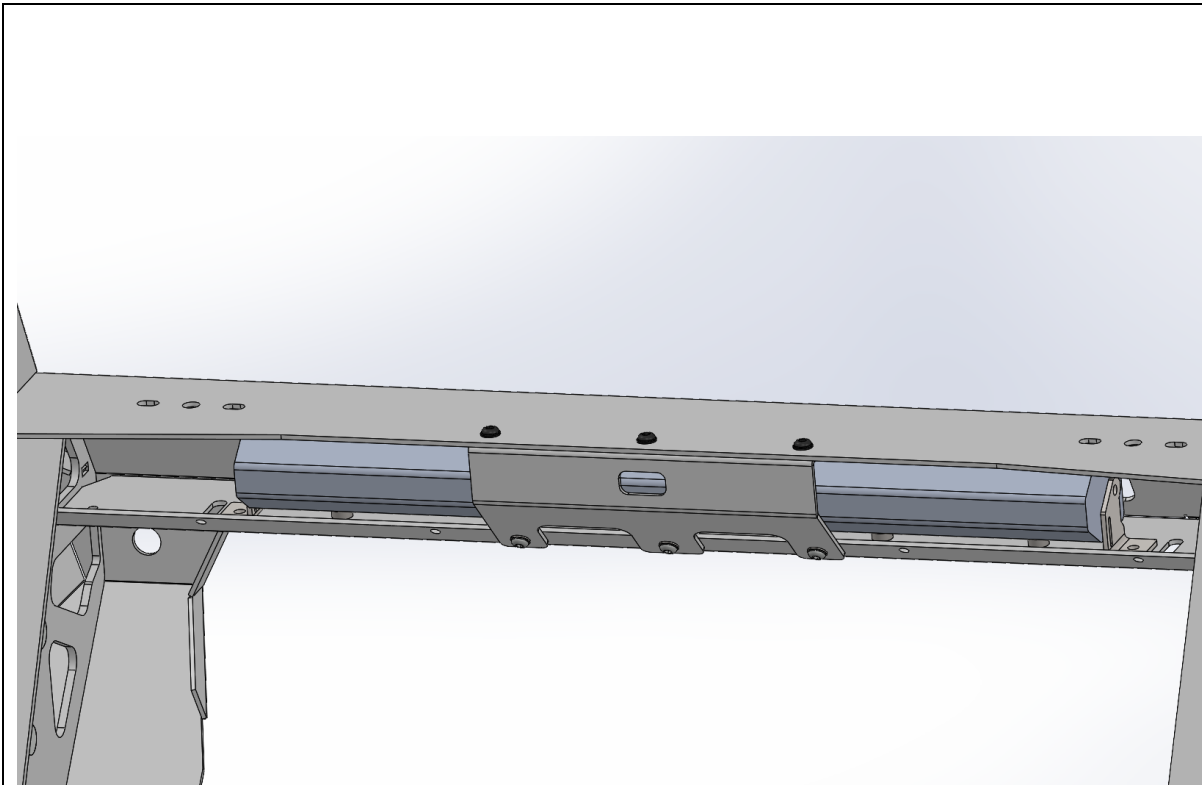

114. If fitting an integrated light bar, do so now.

115. The bar is designed to fit an Offroad Animal 22in or STEDI ST3K 21.5 inch light bar. If fitting this light bar, assemble bar with legs out, and it will line up with the slots in the centre gusset. Secure with M8 Fasteners supplied with the light bar.

116. The bar can accommodate most other “20 inch” size light bars.

117. If fitting driving lights to the bar this is also the most convenient time to do so.

118. Fit the Pan brace to the back of the bar, between the pan and centre gusset, using supplied M6x16 black button head bolts (top) and M6x12 button head bolts (bottom), flat washers and flange nuts.

TOOLS REQUIRED

Supplied with lights

4mm hex/Allen key

FASTENERS

Supplied with lights

3x M6x16 black button head

3x M6 black flat washer

3x M6x12 button head

3x M6 Flat washer

6x M6 flange nut

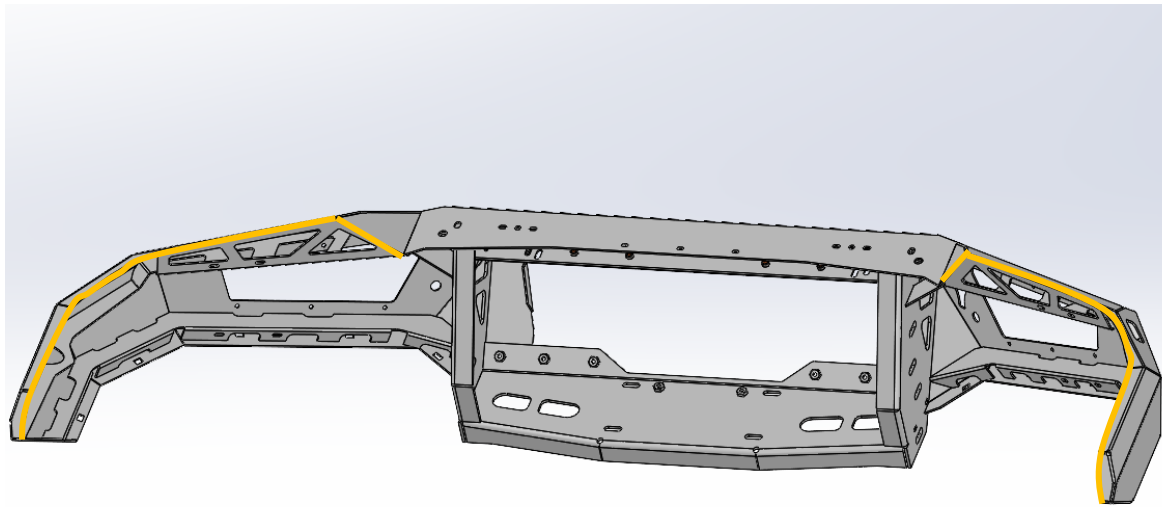

119. Fit pinch weld to extents on top edges of bar shown in image above.

120. Push pinch weld onto edge firmly until it bottoms out. Lightly tapping with hammer can assist in getting all the way on.

TOOLS REQUIRED

Soft face hammer (optional)

FASTENERS



<p>121. With assistance, either from another person, or a lifting trolley, lift the bar onto the mounts on the vehicle.</p> <p>122. Secure with 4x M12x30 Bolts, heavy duty washers and M12 Nyloc and flange nuts per side. Keep all bolts finger tight at this stage.</p> <p>Note: Use 1x Nyloc per side.</p>	<p>TOOLS REQUIRED</p> <p>Lifting Trolley</p>
	<p>FASTENERS</p> <p>8x M12x30 Bolt 10x M12 heavy duty large washer 6x M12 flange nut 2x M12 Nyloc nut</p>

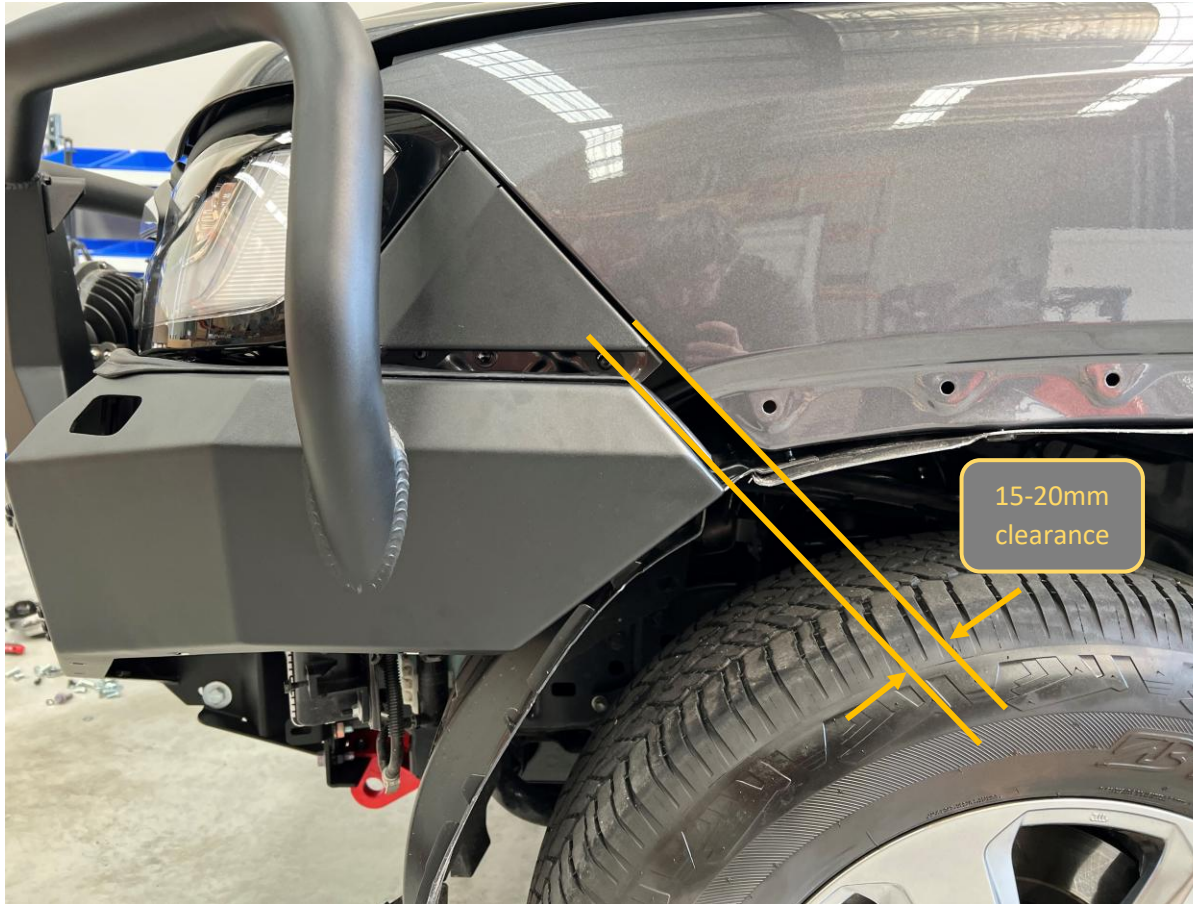

123. With assistance, from another person, align the bar with the edges of the vehicle. Adjust such that the clearances are neat and even side to side.

Acceptable range of clearances shown in image above.

124. Once in position, tighten the M12 Bolts using socket and spanner. An impact driver may be used to speed up this process.

TOOLS REQUIRED

Lifting Trolley

18/19mm socket/spanner

FASTENERS

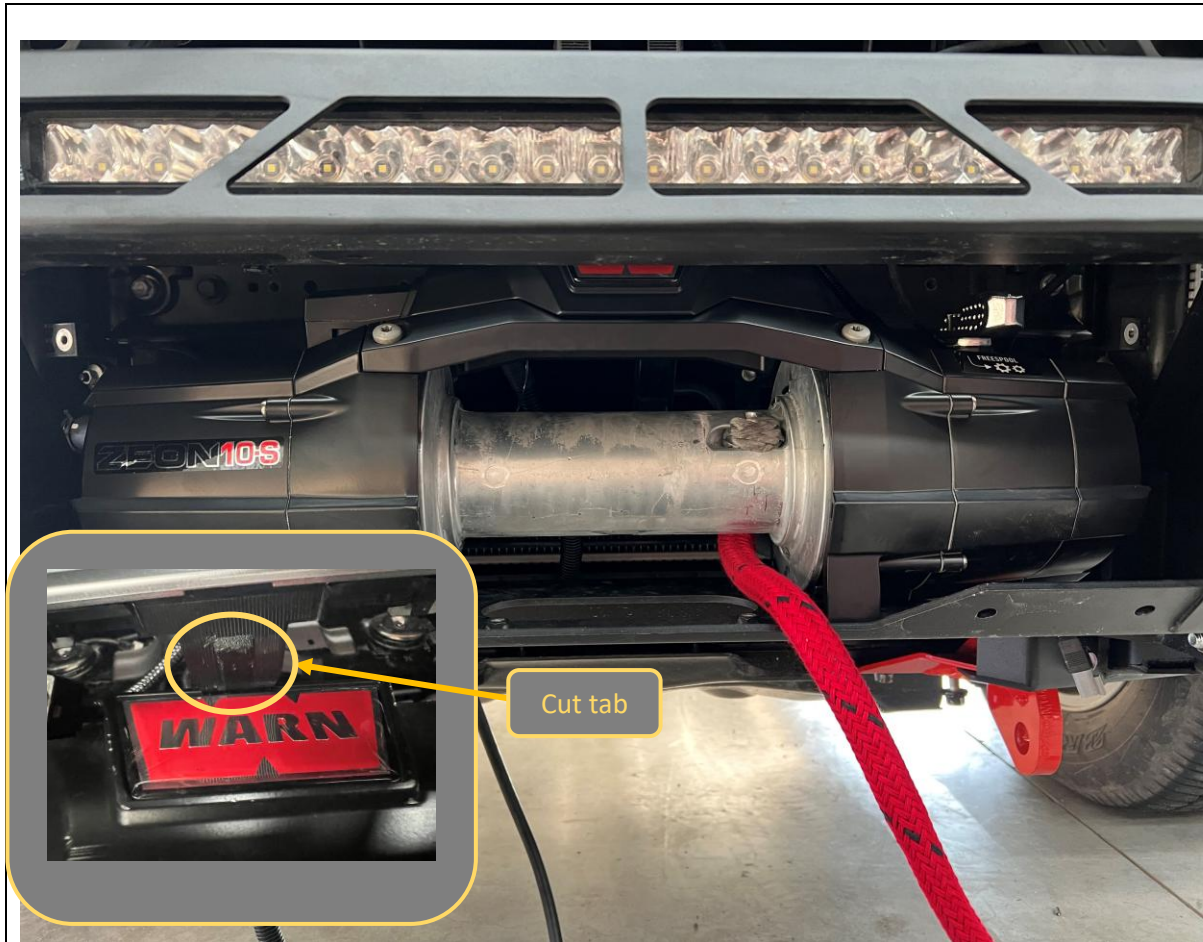

- 125. If fitting a winch, do so now.
- 126. If winch has top mount control box, the centre tab at bottom of grille will need to be cut off to allow clearance. This can be done with side cutters.
- 127. The bar is designed to fit most low mount winches, in foot down configuration. WARN ZEON 10 is largest winch confirmed to fit.
- 128. The control box can be mounted on top of the winch. Winches usually come with a bracket to allow this. Refer to winch manufacturer.
- 129. Ensure clutch handle will be accessible through the access hole in front mesh panel. Refer to winch instructions regarding changing clutch handle location.

TOOLS REQUIRED

Refer to winch fitting instructions

FASTENERS

Supplied with winch



130. If required, fit winch fairlead to mesh fairlead mount using M10 or 3/8" fasteners supplied with winch. The bar is only compatible with hawse type fairleads.

131. If equipped fit the front camera removed earlier to the mesh fairlead mount using 2x M6x16 black button head bolts, black flat washers, and flange nuts.

132. Fit number plate flip bracket to fairlead mount, using 2x M8x25 hex bolts, 4x flat washers, 2x Nylon washers and 2x Nyloc nuts. Ensure nylon washer sits between the bracket and fairlead mount.

TOOLS REQUIRED

4mm hex/Allen Key

13mm spanner

FASTENERS

2x M6x16 black button head

2x M6 black flat washer

2x M6 flange nut

2x M8x25 hex bolt

4x M8 flat washer

2x M8 nylon washer

2x M8 Nyloc nut



133. As the mesh panel is offered up to the bar, re-connect the front camera wiring harness, if equipped.

134. Fit the mesh fairlead mount to the centre of the bar, using 2x M8x16 black button head and black washers at the top; and 2x M8x20 hex bolts and flat washers at the bottom.

135. Tighten fasteners using 5mm Allen key.

TOOLS REQUIRED

5mm hex/Allen key

FASTENERS

2x M8x16 black button head
2x M8 black flat washer

2x M8x20 hex head
2x M8 flat washer

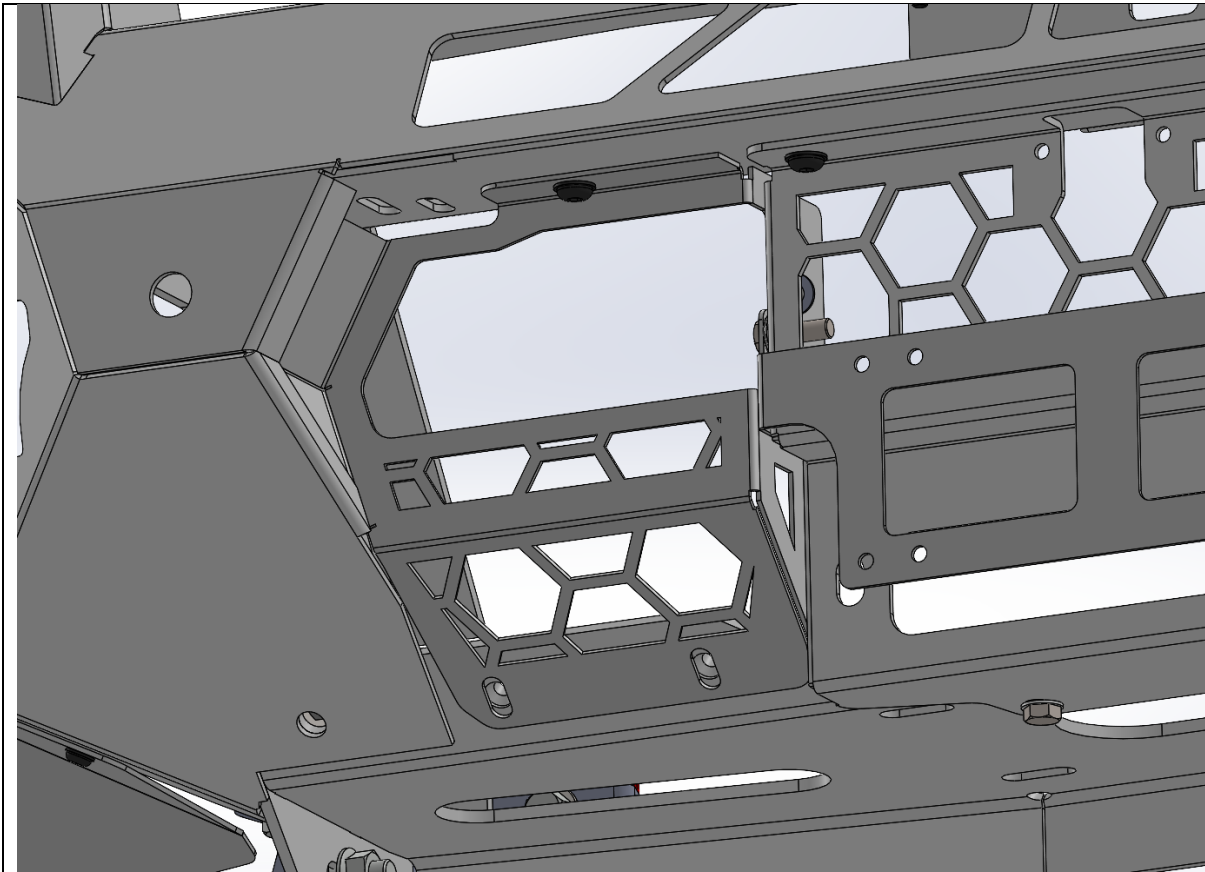

136. Fit each side mesh infill panel using 1x M8x16 black button head bolt and black flat washer into the captive thread in the top of the bull bar.

137. Don't fit any bolts to bottom holes at this stage.

138. Tighten top fasteners using 5mm Allen key.

TOOLS REQUIRED

5mm hex/Allen key

FASTENERS

2x M8x16 button head
2x M8 black flat washer

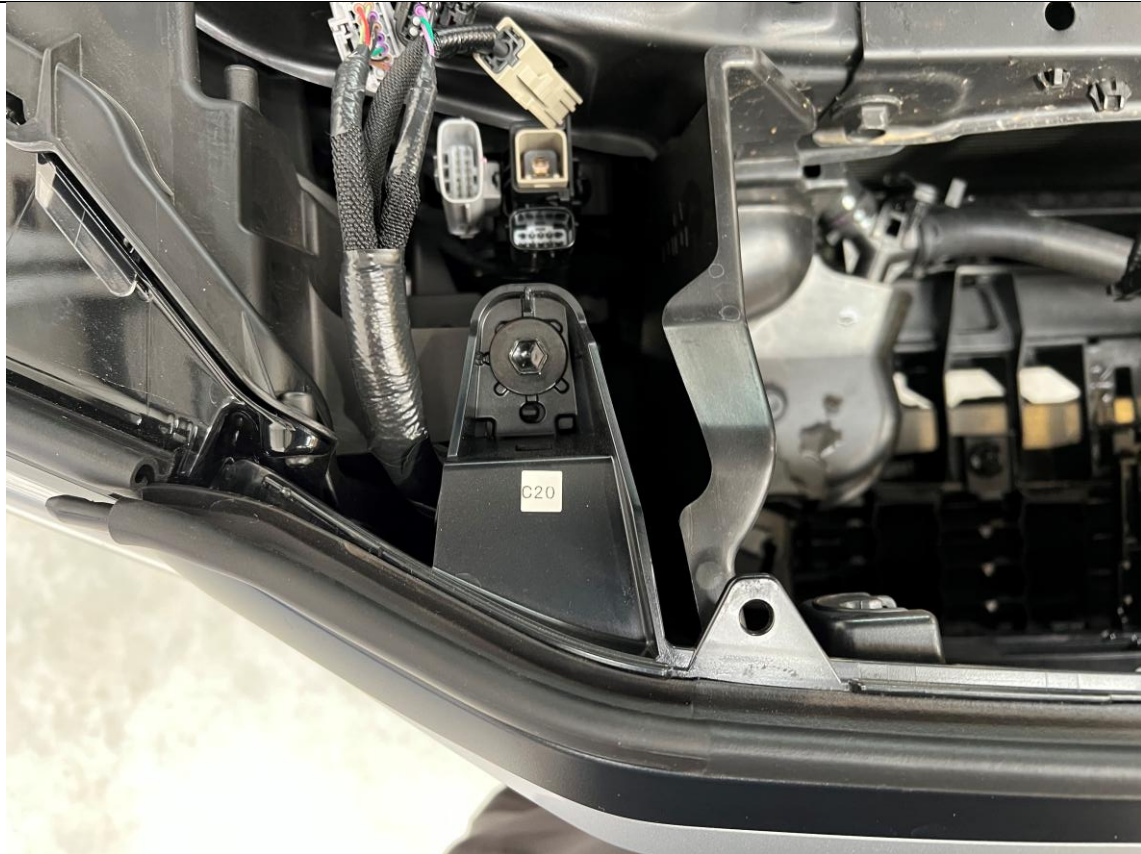

139. Re-connect electrical harness, fog lights and headlight washer hose at the top of grille.

140. Replace upper radiator cowl using original clips.

TOOLS REQUIRED

FASTENERS

Factory clips (re-use)



- 141. Re-fit parking sensors to housings mounted in the bar, reaching from underneath the wing to do so.
- 142. Reconnect wiring harnesses and cable tie harnesses neatly.

TOOLS REQUIRED

Cable ties

FASTENERS

Factory clips (re-use)



143. Remove 4x factory bolts securing the bottom of the tow point to the cross member.
144. Fit the centre bash plate using 6x M8x30 black button head bolts and black flat washers on the front face. Ensure these fasteners pass through the side mesh panels also.
145. Secure the back of the centre bash plate using the flange factory bolts removed earlier. The bash plate should sit immediately below the tow point.
146. Tighten bottom fasteners using 17mm socket.
147. Tighten front fasteners using 5mm Allen key.

TOOLS REQUIRED

- 17mm socket/spanner
- 5mm hex/Allen key

FASTENERS

- 6x M8x30 black button head
- 6xM8 black flat washer



148. Loosely fit each side underpanel to the underside of the bullbar wings using 5x M6x16 black button head bolts and black flat washers into the cage nuts placed earlier.

149. Secure the inner back of the side underpanel to the impact assembly using 1x M8x20 hex bolt, flat washer, and flange nut.

150. Leave finger tight at this stage.

TOOLS REQUIRED

FASTENERS

10x M6x16 black button head
10x M6 black flat washer

2x M8x20 hex head
2x M8 flat washer
2x M8 flange nut



151. Using the edge of the side underpanel as a guide, mark the wheel arch liner, approximately 15mm beyond the intersection of the underpanel.

152. Cut along line as marked using utility knife.

153. Tuck the wheel arch liner behind the flange on the underpanel.

154. Tighten all underpanel bolts.

155. Complete for other side of vehicle.

TOOLS REQUIRED

Utility knife

4mm hex/Allen key
13mm socket/spanner

FASTENERS



<p>156. Using the masking tape and markings made earlier in step 12 setup to trim the flare.</p> <p>157. Cut along edge marked using oscillating multi tool, air hacksaw or angle grinder. Take care to ensure a straight cut and neat edge.</p> <p>158. Re-Fit the wheel arch flare to the vehicle using the original clips</p>	<p>TOOLS REQUIRED</p> <p>Power Cutting Tool</p>
<p>159. Complete flare trim and re-fitment on other side of vehicle.</p>	<p>FASTENERS</p> <p>OE Clips – re use</p>

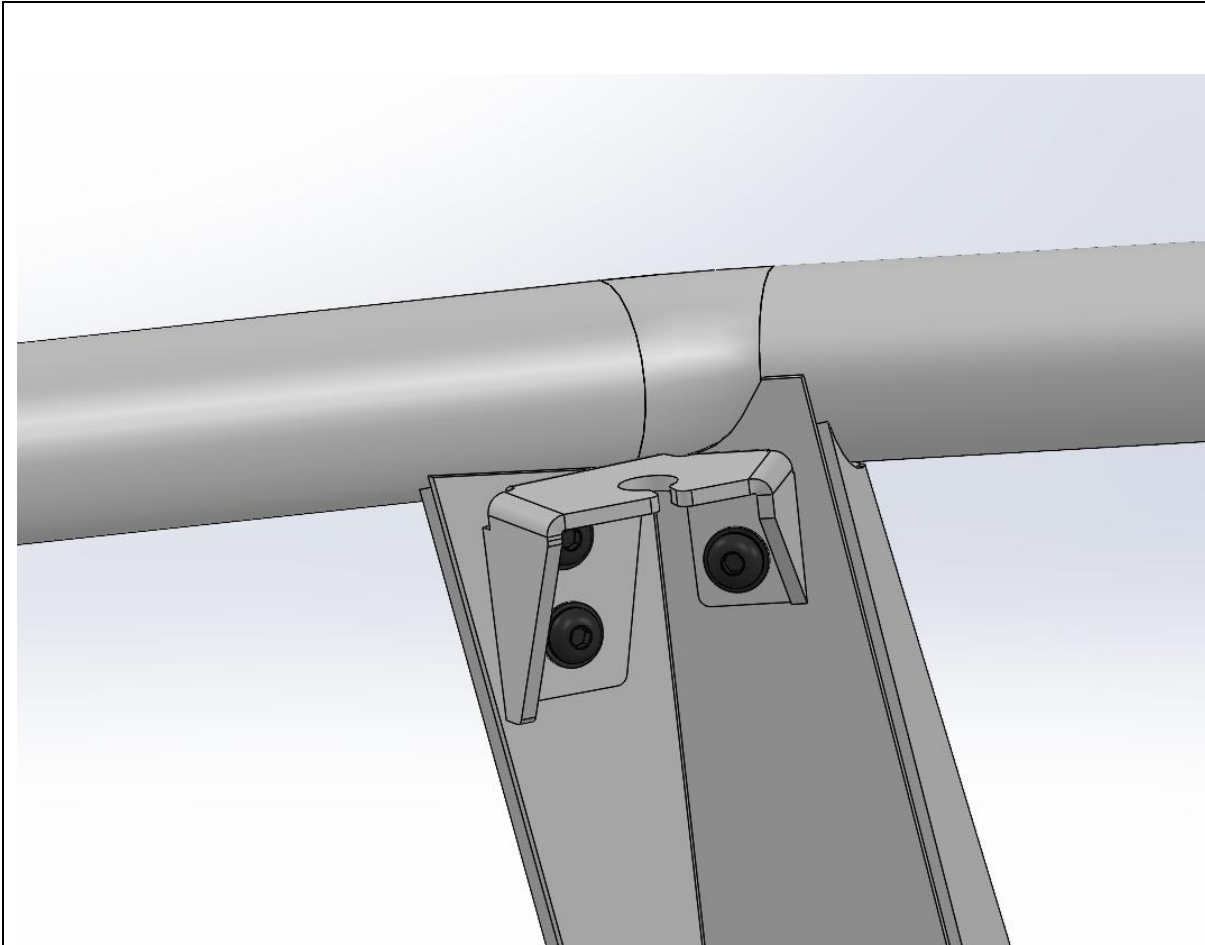

160. **Toro only.** If fitting antenna to Toro bar, fit the antenna brackets to the M8 Threaded inserts in the uprights using 3x M8x20 black button head bolts and black washers.
161. **Toro only.** Else fit the 3x M8x20 black button head bolts and black washers to the back of each bullbar upright, to protect nut threads in bar for future use.
162. Fit antenna to the bracket as per antenna manufacturer's instructions.
163. Retain unused brackets for future use.

TOOLS REQUIRED

5mm hex/Allen key

FASTENERS

3x M8x20 black button head
3x M8 black flat washer



Do not forget compliance plate

164. Check all fasteners are tight.
165. Re-fit number plate to number plate flip.
166. Fit the compliance plate in a visible location on the underside of the bar. We recommend placing it on the bottom of the centre bash plate.
167. Head out bush and enjoy your newly protected LandCruiser!

For contact details see www.offroadanimal.com